



# Z107-107

## 20 [508] WIDE DECK FLANGEROOF DRAIN WITH S.S. PERF. DOME & S.S MESH SCREEN

TAG \_\_\_\_\_

Dimensional Data (inches and [ mm ]) are Subject to Manufacturing Tolerances and Change Without Notice

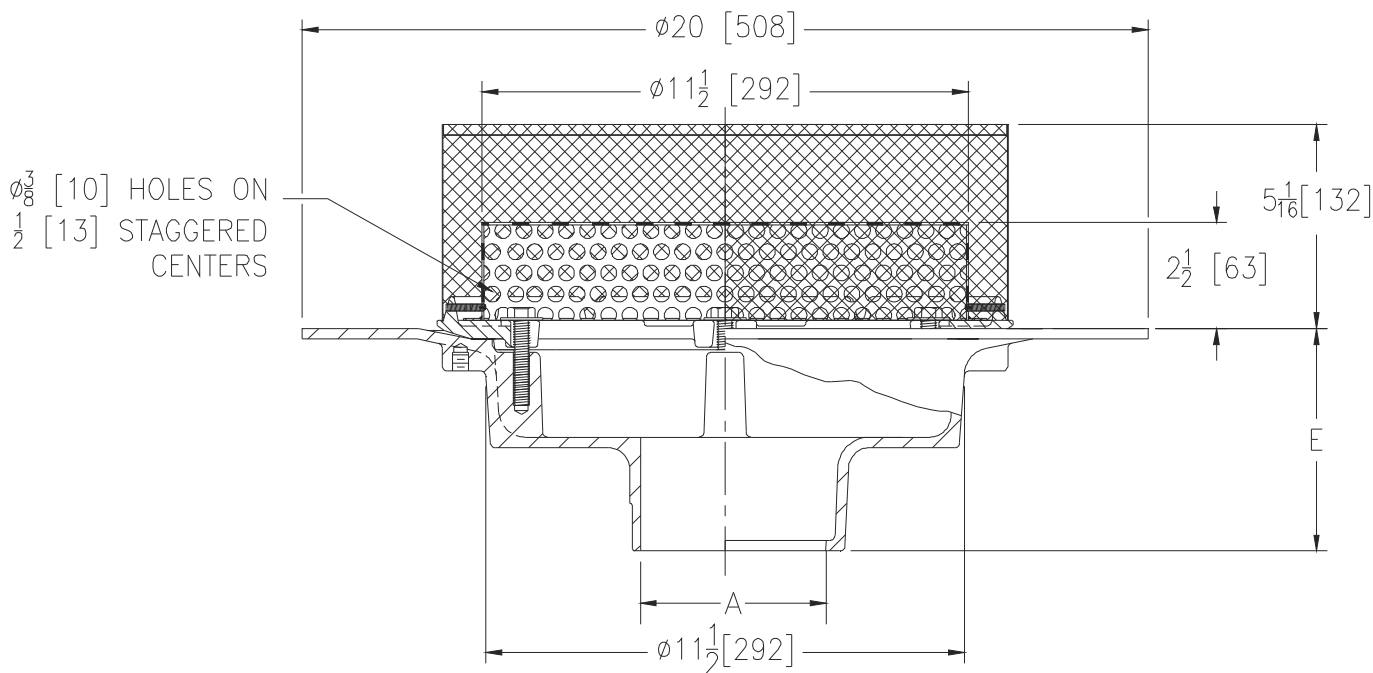

A- Pipe Size In.	Approx. Wt. Lbs. [kg]	Dome Open Area Sq. In. [cm <sup>2</sup> ]
3-4 [75-100]	39 [18]	103 [665]
6-8 [150-200]		

**ENGINEERING SPECIFICATION: ZURN Z107-107**  
20 [508] Diameter wide deck flange roof drain. Dura-Coated cast iron with combination membrane flashing clamp/gravel guard and stainless steel perforated dome with stainless steel mesh screen.

**OPTIONS** (Check/specify appropriate options)

**PIPE SIZE**

3,4,6 [75,100,150]  
3,4,6,8 [75,100,150,200]

(Specify size/type) **OUTLET**

\_\_\_\_\_ IC Inside Caulk  
\_\_\_\_\_ NH No-Hub

**E BODY HT. DIM.**

5 1/4 [133]  
5 1/4 [133]

**PREFIXES**

\_\_\_ Z D.C.C.I. Body with Stainless Steel Perforated Dome\*

**SUFFIXES**

- \_\_\_ -AC Angular Underdeck Clamp
- \_\_\_ -AR Acid Resistant Epoxy Coated Finish
- \_\_\_ -AW 3/4 [19] to 4 [102] Adjustable Water Level Regulator
- \_\_\_ -BS Bronze Mash Screen Over Dome
- \_\_\_ -C Underdeck Clamp
- \_\_\_ -E Static Extension 1 [25] thru 4 [102] (Specify Ht.)
- \_\_\_ -EA Adjustable Extension Assembly  
1-3/4 [44] thru 3-1/2 [89]
- \_\_\_ -G Galvanized Cast Iron
- \_\_\_ -VP Vandal Proof Secured Top
- \_\_\_ -89 2 [51] High External Water Dam

REV.	DATE: 02/06/13	C.N. NO. 128757
DWG. NO. 311630		PRODUCT NO. Z107-107

\*REGULARLY FURNISHED UNLESS OTHERWISE SPECIFIED