



# Z415I-Y

## BODY ASSEMBLY W/ "TYPE I" STRAINER AND SEDIMENT BUCKET

SPECIFICATION SHEET

TAG \_\_\_\_\_

Dimensional Data (inches and [ mm ]) are Subject to Manufacturing Tolerances and Change Without Notice

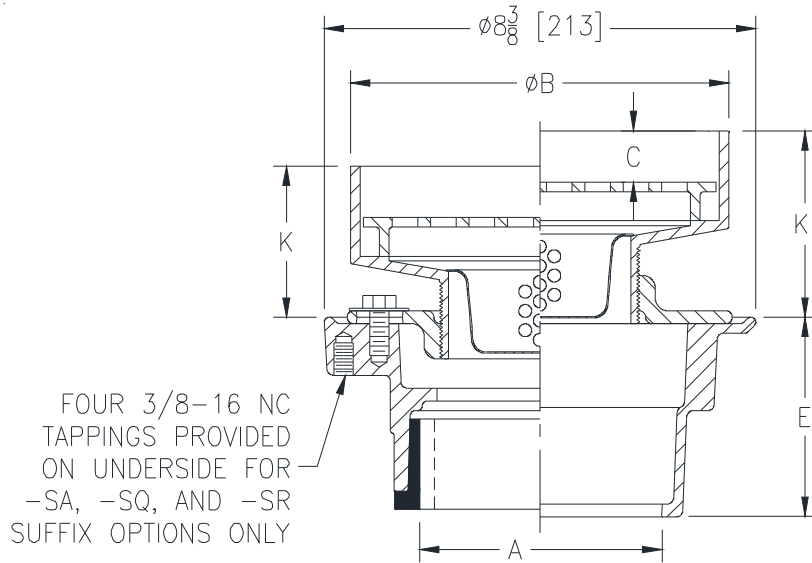

Dimension in Inches [mm]							Approx. Wt. Lbs. [kg]	Strainer Open Area Sq. In. [cm <sup>2</sup> ]
A - Pipe Size	B - Strainer Diameter	C	K		K'			
			Min.	Max.	Min.	Max.		
2,3 [51,76]	5-7/16 [138]	7/8 [22]	1-9/16 [40]	2-5/8 [67]	2-1/8 [54]	3-3/8 [86]	14 [6]	8 [52]
2,3,4 [51,76,102]	7-3/8 [187]	1 [25]	2-9/16 [65]	3-3/8 [86]	2-7/8 [73]	4-1/8 [105]	19 [9]	13 [84]
3,4,6 [76,102,152]	9 [229]	1/2 [13]	2-3/16 [56]	3-1/8 [79]	2-5/8 [67]	3-7/8 [98]	23 [10]	23 [148]

### ENGINEERING SPECIFICATION: ZURNZN415I-Y

Floor and shower drain, Dura-Coated cast iron body with bottom outlet, combination invertible membrane clamp and adjustable collar with seepage slots and "TYPE I" polished nickel bronze strainer with raised flange and sediment bucket.

### OPTIONS (Check/specify appropriate options)

PIPE SIZE	(Specify size/type) OUTLET	'E' BODY HT. DIM.
2,3,4 [51,76,102]	_____ IC Inside Caulk	4-13/16 [106]
2 [51]	_____ IP Threaded	2-7/16 [62]
3 [76]	_____ IP Threaded	2-3/4 [70]
4 [102]	_____ IP Threaded	2-13/16 [71]
6 [152]	_____ IP Threaded	2-7/8 [73]
2,3,4 [51,76,102]	_____ NH No-Hub	3-13/16 [97]
2,3,4 [51,76,102]	_____ NL Neo-Loc	3-7/8 [98]

### PREFIXES

- \_\_\_\_\_ ZB D.C.C.I. Body Assembly w/ Polished Bronze Top
- \_\_\_\_\_ ZN D.C.C.I. Body Assembly w/ Polished Nickel Bronze Top\*

### SUFFIXES

- |   |   |
|---|---|
| _____ -AR Acid Resisting Epoxy Coated Cast Iron                                 | _____ -TS Top Secured with Slotted Screws             |
| _____ -G Galvanized Cast Iron   | _____ -U 1 thru 3 [25 thru 76] High Extension Adapter |
| _____ -P Trap Primer Connection (Specify 1/2 [13] or 3/4 [19])                  | _____ -V Backwater Valve                              |
| _____ -SA Stabilizer Assembly (See Z1035)                                       | _____ -VP Vandal-Proof Secured Top                    |
| _____ -SQ Stabilizer Q-Deck (See Z1035-Q)                                       | _____ -90 90° Threaded Side Outlet Body               |
| _____ -SR Stabilizer Ring   | Assembly (2 [51], 3 [76] Only)                        |
| _____ -TC Neo-Loc Test Cap Gasket (2, 3, 4 [51, 76, 102] NL Bottom Outlet Only) |   |

\* Regularly furnished unless otherwise specified.