



Z100-288

15 [381] DIAMETER MAIN ROOF DRAIN W/ THREADED STANDPIPE, Z125 UPPER ASS'Y, & STATIC EXTENSION W/ SECONDARY CLAMP COLLAR

SPECIFICATION SHEET

TAG _____

Dimensional Data (inches and [mm]) are Subject to Manufacturing Tolerances and Change Without Notice

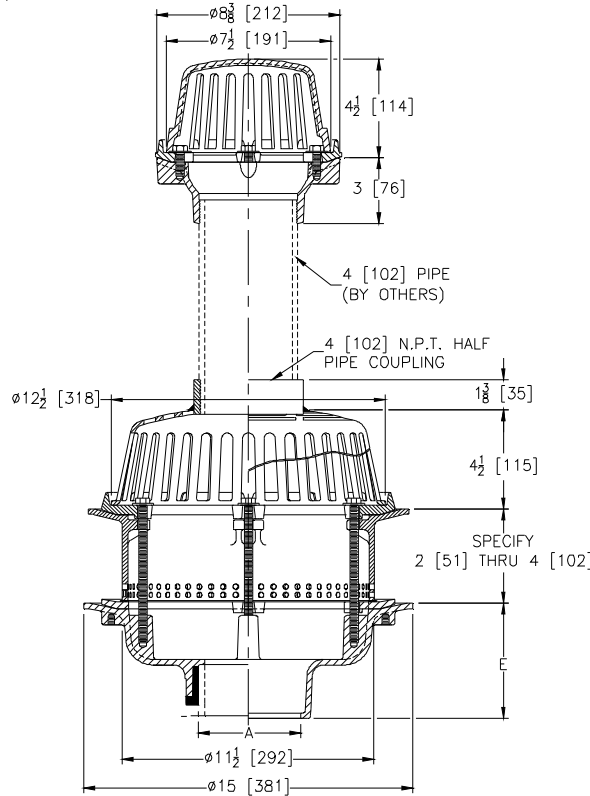

A Pipe Size In.	Approx. Wt. Lbs. [kg]	Dome Open Area Sq. In. [cm ²]
2-3-4 [51-76-102]	40 [18]	43 [227]
5-6 [127-152]	39 [17]	

ENGINEERING SPECIFICATION: ZURN Z100-288

15 [381] Diameter roof drain. Dura-Coated cast iron body with combination membrane flashing clamp/gravel guard, low silhouette cast iron dome with threaded standpipe, and static extension w/ secondary clamp. Upper assembly is 8-3/8 [213] Diameter roof drain. Dura-Coated cast iron body with combination membrane flashing clamp/gravel guard and low silhouette poly dome.

OPTIONS (Check/specify appropriate options)

PIPE SIZE

- 2-3-4-5-6 [51-76-102-127-152]
- 2-3-4-5-6 [51-76-102-127-152]
- 2-3-4-5-6 [51-76-102-127-152]
- 2-3-4 [51-76-102]
- 6 [152]

(Specify size/type) OUTLET

- _____ IC Inside Caulk
- _____ IP Threaded
- _____ NH No-Hub
- _____ NL Neo-Loc
- _____ NL Neo-Loc

E BODY HT. DIM.

- 5-1/4 [133]
- 3-3/4 [95]
- 5-1/4 [133]
- 4-9/16 [116]
- 5-7/16 [112]

PREFIXES

- _____ Z D.C.C.I. Body and Dome*

SUFFIXES

- | | | | |
|-----------|---|-----------|---|
| _____ -AC | Angular Underdeck Clamp | _____ -G | Galvanized Cast Iron |
| _____ -AR | Acid Resistant Epoxy Coated | _____ -GD | Galvanized Cast Iron Dome (ZC Only) |
| _____ -BS | Bronze Mesh Screen Over Dome | _____ -R | Roof Sump Receiver |
| _____ -C | Underdeck Clamp | _____ -SS | Stainless Steel Mesh Screen Over Dome |
| _____ -DE | Deck Extension | _____ -TC | Neo-Loc Test Cap Gasket
(2 - 4 [51 - 102] NL Bottom Outlet Only) |
| _____ -DP | Top-Set® Deck Plate (Replaces both the -C and -R) | _____ -VP | Vandal-Proof Secured Top |
| _____ -DR | Top-Set® Drain Riser | _____ -90 | 90° Threaded Side Outlet Body
(2 thru 6 [51 or 152]) |
| _____ -EB | Top-Set® Adjustable Extension Assembly | | |

* Regularly furnished unless otherwise specified.

Zurn Industries, LLC | Specification Drainage Operation
 1801 Pittsburgh Avenue, Erie, PA U.S.A. 16502 · Ph. 855-663-9876, Fax 814-454-7929
 In Canada | Zurn Industries Limited
 3544 Nashua Drive, Mississauga, Ontario L4V 1L2 · Ph. 905-405-8272, Fax 905-405-1292
www.zurn.com

Rev. -
 Date: 05/19/14
 C.N. No. 130993
 Prod. | Dwg. No. Z100-288