



Z-100-157
15" [381] DIAMETER MAIN
ROOF DRAIN W/ HANGING BUCKET

SPECIFICATION SHEET

TAG _____

Dimensional Data (inches and [mm]) are Subject to Manufacturing Tolerances and Changes Without Notice

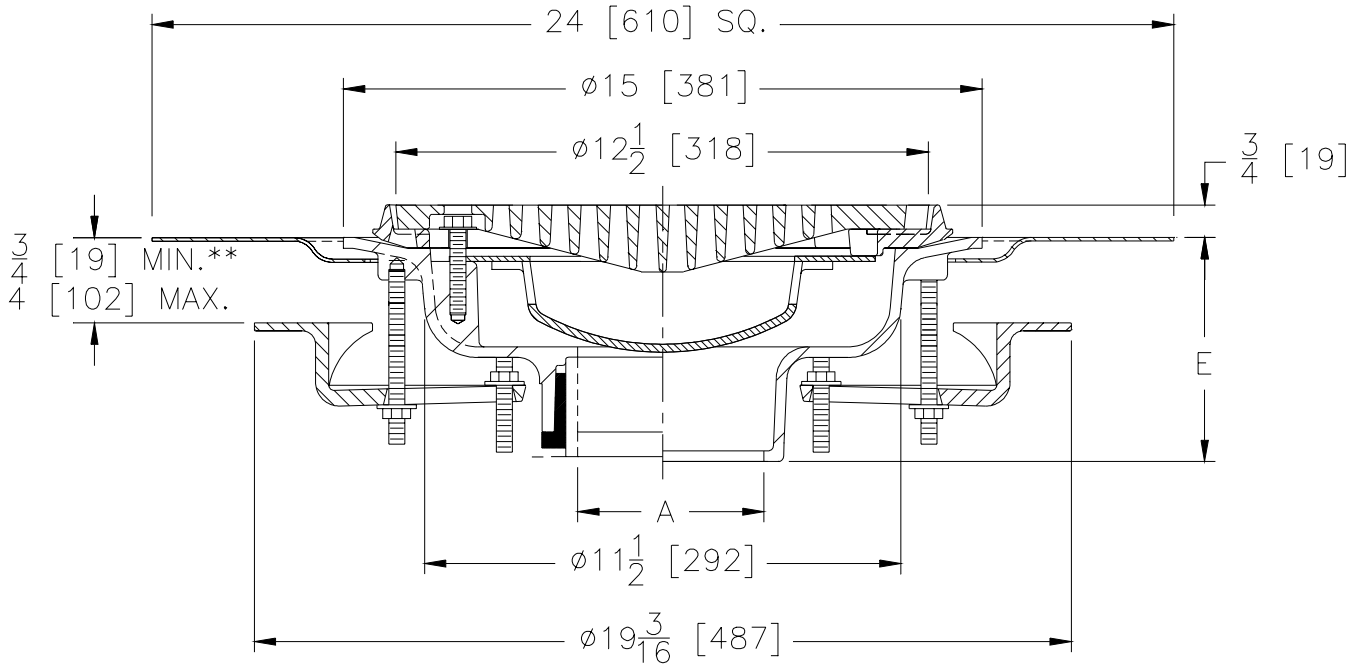

A- Pipe Size In.	Approx. Wt. Lbs. [kg]	Grate Open Area Sq. In. [cm ²]
2-3-4 [50-75-100]	49 [23]	29 [187]
6 [150]	50 [24]	

ENGINEERING SPECIFICATION: ZURN Z-100-157
 15" [381] Diameter roof drain. Dura-Coated cast iron body with combination membrane flashing clamp/gravel guard with underdeck clamp, roof sump receiver, grate and hanging bucket.

OPTIONS (Check/specify appropriate options)

PIPE SIZE

- 2 thru 6 [50 thru 150]
- 2 thru 6 [50 thru 150]
- 2 thru 6 [50 thru 150]
- 2, 3, 4 [50, 75, 100]

(Specify size/type) **OUTLET**

- ___ IC Inside Caulk
- ___ IP Threaded
- ___ NH No-Hub
- ___ NL Neo-Loc

E BODY HT. DIM.

- 5 1/4 [133]
- 3 3/4 [95]
- 5 1/4 [133]
- 4 5/8 [117]

PREFIXES

- ___ Z- D.C.C.I. Body with Grate*

SUFFIXES

- ___ -E Static Extension 1 [25] thru 4 [102] (Specify Ht.)
- ___ -EA Adjustable Extension Assembly 1 3/4 [44] thru 3 1/2 [89]
- ___ -S Secondary Strainer
- ___ -XJ Vertical Expansion Joint (See Z-190)
- ___ -85 Stainless Steel Perforated Extension
- ___ -90 90° Threaded Side Outlet Body

*REGULARLY FURNISHED UNLESS OTHERWISE SPECIFIED

REV.	DATE: 4/6/01	C.N. NO. 87596
DWG. NO. P-14823 PRODUCT NO. Z-100-157		