



# Z1181-90

## SOLIDS INTERCEPTOR W/INTEGRAL EXTENSION

SPECIFICATION SHEET

TAG \_\_\_\_\_

Dimensional Data (inches and [ mm ]) are Subject to Manufacturing Tolerances and Change Without Notice

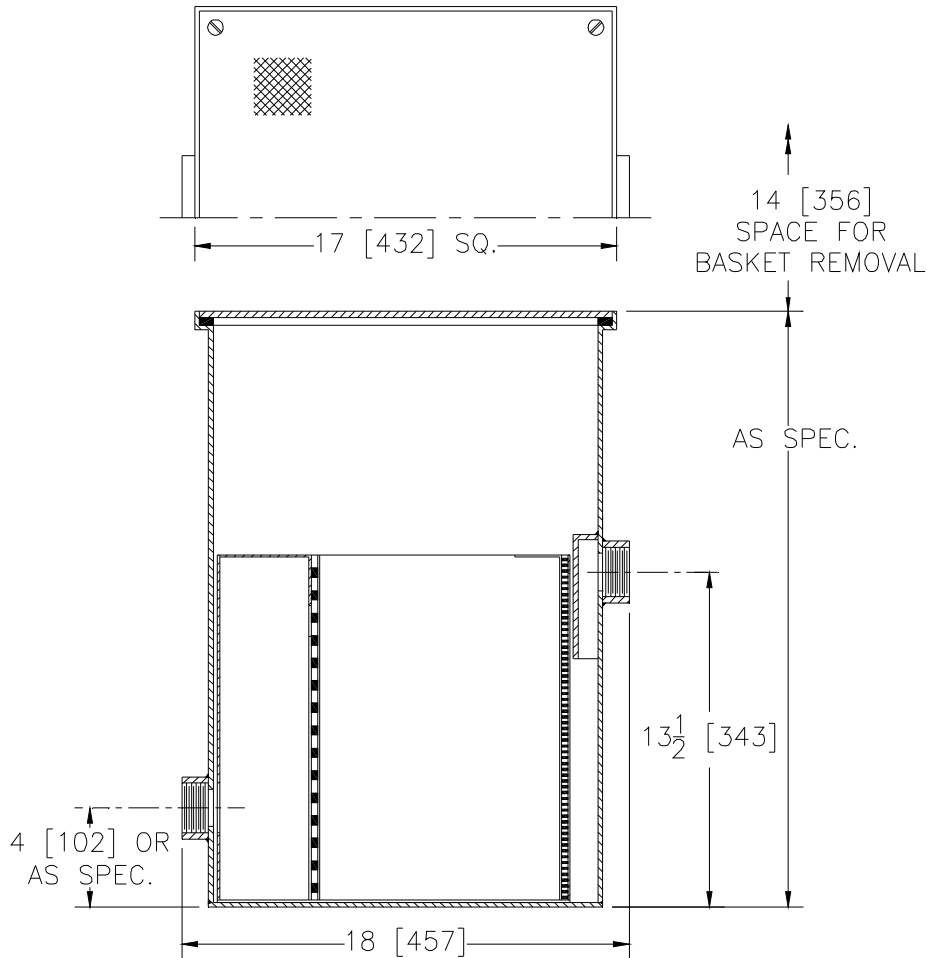

Inlet/Outlet Inches	Flow Rate GPM [L]	Approx. Wt. Lbs. [kg]
1-1/2, 2**,3 [38, 50,75]	30 [113]	40 [18]

**ENGINEERING SPECIFICATION:** ZURN Z1181-90 Large capacity Acid Resistant Coated interior and exterior fabricated steel solids interceptor with integral extension, in lieu of fixture 'P' trap, for on-floor or flush with floor installation. Furnished with a removable Acid Resistant Coated fabricated steel bucket having removable primary (3/8 [10] dia. holes) and secondary (3/32 [2] dia. holes) flow diffusing/intercepting brass screens, and complete with a top access gasketed secured cover. Regularly furnished with 2 [50] low inlet and high outlet\*\*.

**OPTIONS** (Check/specify appropriate options)

**PREFIXES**

\_\_\_ Z Standard Assembly\* (See Engineering Specification)

**SUFFIXES**

- \_\_\_ -CS Custom Screens (Specify material & perforation size required)
- \_\_\_ -SS Stainless Steel Perforated Screens for Bucket (Specify perforation size)
- \_\_\_ -YR Replacement Basket Assembly with Perforated Screens

**NOTE:** 14 [356] space for basket removal may increase as overall height increases.

REV.	DATE: 6/29/09	C.N. NO. 120112
DWG. NO. P-15728 PRODUCT NO. Z1181-90		

\*REGULARLY FURNISHED UNLESS OTHERWISE SPECIFIED