



Z100-331

15 [381] DIAMETER MAIN ROOF DRAIN LOW SILHOUETTE DOME
W/UNDERDECK CLAMP, ADJUSTABLE EXTENSION, SEDIMENT
BUCKET AND EXTERNAL WATER DAM

SPECIFICATION SHEET

TAG _____

Dimensional Data (inches and [mm]) are Subject to Manufacturing Tolerances and Change Without Notice

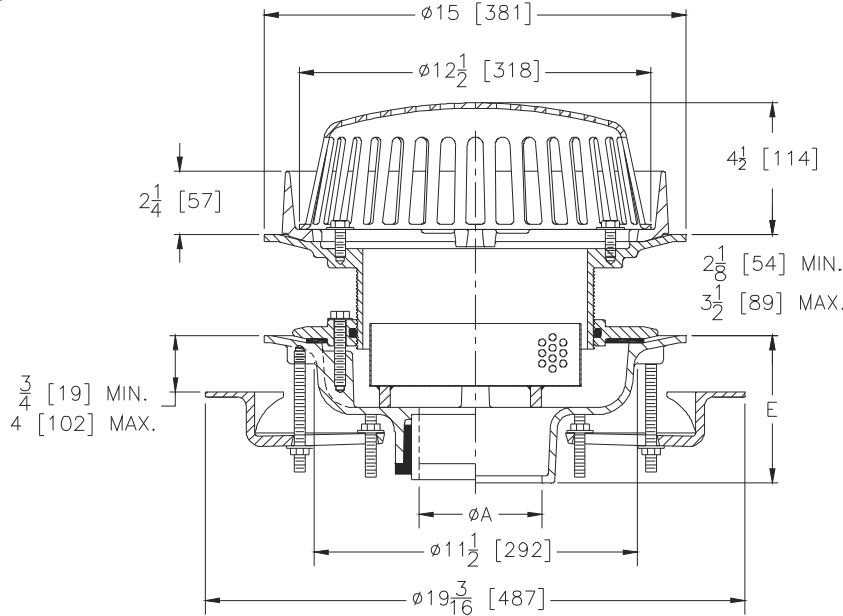

A Pipe Size In. [mm]	Approx. Wt. Lbs. [kg]	Dome Open Area Sq. In. [cm ²]
2,3,4 [51,76,102]	60 [27]	103 [665]
5,6 [127,152]	60 [27]	
8 [203]	60 [27]	

ENGINEERING SPECIFICATION: ZURN Z100-331

15" [381mm] Diameter roof drain. Dura-Coated cast iron body with combination membrane flashing clamp/gravel guard, adjustable extension, underdeck clamp, low silhouette Poly-Dome, sediment bucket and external water dam.

OPTIONS (Check/specify appropriate options)

PIPE SIZE

- 2,3,4,5,6,8 [51,76,102,127,152,203]
- 2,3,4,5,6,8 [51,76,102,127,152,203]
- 2,3,4,5,6,8 [51,76,102,127,152,203]
- 2,3,4 [51,76,102]
- 6 [152]

(Specify size/type) OUTLET

- _____ IC Inside Caulk
- _____ IP Threaded
- _____ NH No-Hub
- _____ NL Neo-Loc
- _____ NL Neo-Loc

E BODY HT. DIM.

- 5-1/4 [133]
- 3-3/4 [95]
- 5-1/4 [133]
- 4-9/16 [116]
- 5-7/16 [112]

PREFIXES

- _____ Z D.C.C.I. Body with Poly-Dome*
- _____ ZA D.C.C.I. Body with Aluminum Dome
- _____ ZC D.C.C.I. Body with Cast Iron Dome
- _____ ZRB D.C.C.I. Body with Plain Bronze Dome

SUFFIXES

- _____ -AR Acid Resistant Epoxy Coated
- _____ -AW 3/4 [19] to 4 [102] Adj. Water Level Regulator (Specify Height) (ZC Only)
- _____ -BS Bronze Mesh Screen Over Dome
- _____ -DX Dex-o-tex Flange
- _____ -FG Flush Grate (Replaces Dome Strainer)
- _____ -G Galvanized Cast Iron
- _____ -GD Galvanized Cast Iron Dome (ZC Only)
- _____ -HD 6-3/4 [171] High Aluminum Dome Strainer (148 Sq. In. [955 cm²] Open Area) (ZA Only)
- _____ -R Roof Sump Receiver
- _____ -SC Secondary Clamp Collar
- _____ -SS Stainless Steel Mesh Screen Over Dome
- _____ -ST Dome with Solid Top (ZA, ZC & ZRB Only)
- _____ -TC Neo-Loc Test Cap Gasket (2 - 4 [51 - 102] NL Bottom Outlet Only)
- _____ -VP Vandal-Proof Secured Top
- _____ -90 90° Threaded Side Outlet Body (2 thru 6 [51 or 152])

* Regularly furnished unless otherwise specified.