



Z-1719-77

DECK DRAIN WITH WIDE FLANGE

SPECIFICATION SHEET

TAG _____

Dimensional Data (inches and [mm]) are Subject to Manufacturing Tolerances and Change Without Notice

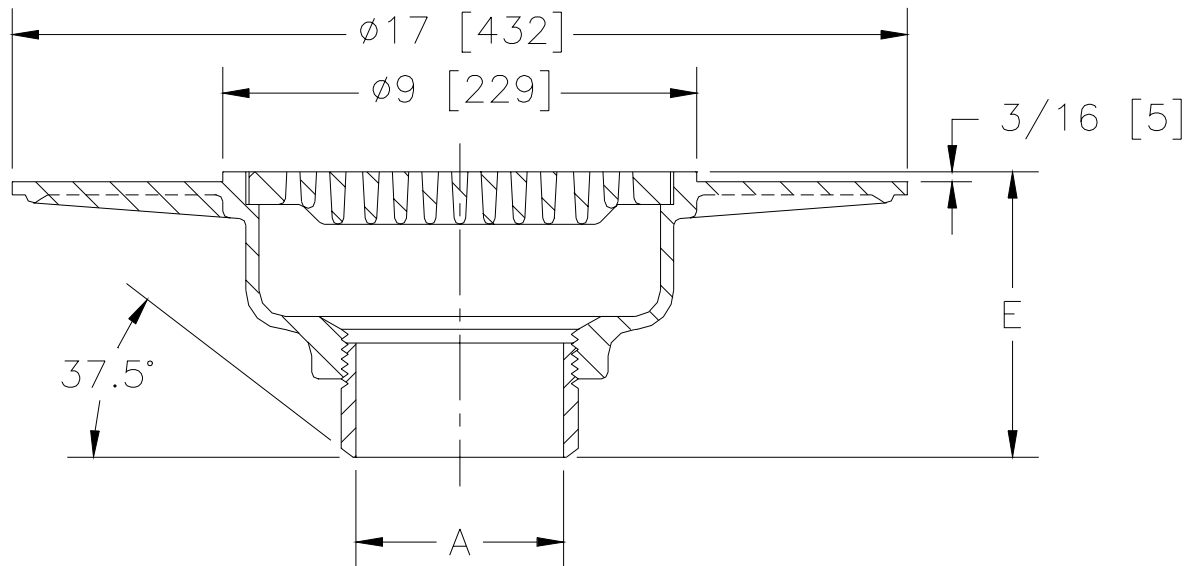

A- Pipe Size In.	Approx. Wt. Lbs. [kg]	Grate Open Area Sq. In. [cm ²]
2-3-4 [50-75-100]	22 [10]	17 [110]

ENGINEERING SPECIFICATION: ZURN Z-1719-77 All Type 304 (CF8) stainless steel deck drain with 17 [432] diameter flange and medium duty flat grate with plain finish.

OPTIONS (Check/specify appropriate options)

PIPE SIZE

(Specify size/type) **OUTLET**

'E' BODY HT. DIM.

2 thru 4 [50 thru 100]

_____ BW Butt Weld

5-1/2 [140]

PREFIXES

- _____ Z- Type 304 (CF8) Stainless Steel Body*
- _____ ZC- Type A-27 Carbon Steel Body (P.O.A.)
- _____ ZM- Type 316 (CF8M) Stainless Steel Body

SUFFIXES

- _____ -SF Satin Finish Top
- _____ -VP Vandal Proof Secured Top
- _____ -Y Sediment Bucket

REV.	DATE: 9/7/00	C.N. NO. 85859
DWG. NO. P-14796 PRODUCT NO. Z-1719-77		

*REGULARLY FURNISHED UNLESS OTHERWISE SPECIFIED