



Z125-103
8 3/8 [213] DIAMETER ROOF DRAIN W/STAINLESS STEEL
PERFORATED PLATE AND 4 [102] NO-HUB ADAPTER

SPECIFICATION SHEET

TAG _____

Dimensional Data (inches and [mm]) are Subject to Manufacturing Tolerances and Change Without Notice

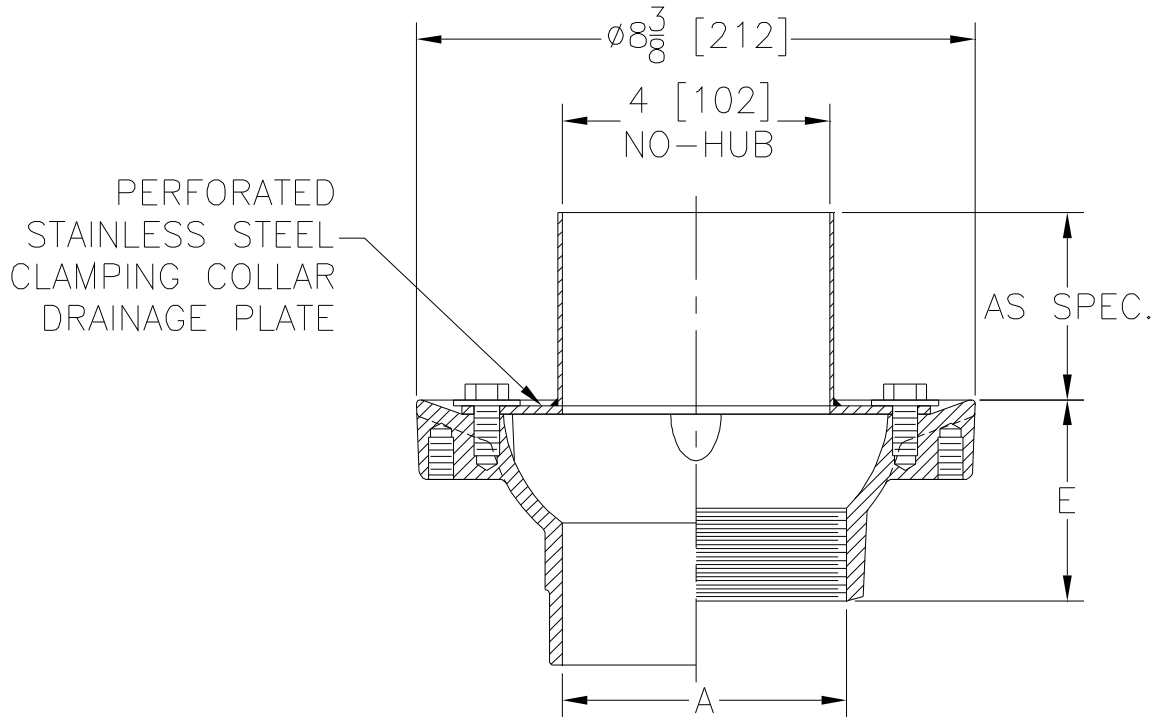

A Pipe Size In.	Approx. Wt. Lbs. [kg]
3-4 [76-102]	14 [6]

ENGINEERING SPECIFICATION: ZURN Z125-103

8 3/8 [213] Diameter roof drain, Dura-Coated cast iron body with stainless steel perforated plate with 4 [102] No-Hub adapter.

OPTIONS (Check/specify appropriate options)

PIPE SIZE

(Specify size/type) **OUTLET**

'E' BODY HT. DIM.

4 [102]	_____ IP Threaded	3 [76]
3 [76]	_____ IP Threaded	2 3/4 [70]
3-4 [51-76-102]	_____ NH No-Hub	4 [102]

PREFIXES

_____ Z D.C.C.I. Body

SUFFIXES

- _____ -AR Acid Resistant Epoxy Coated Finish
- _____ -C Underdeck Clamp
- _____ -DP Top-Set® Roof Deck Plate
(Replaces both the -C and -R)
- _____ -DR Top-Set® Drain Riser
- _____ -EB Top-Set® Adjustable Extension Assembly
- _____ -G Galvanized Cast Iron
- _____ -R Roof Sump Receiver
- _____ -VP Vandal Proof Secured Top
- _____ -XJ Vertical Expansion Joint (See Z190)
- _____ -90 90° Threaded Side Outlet Body
(2 - 4 [51 - 102]) (Previously Z126)

*REGULARLY FURNISHED UNLESS OTHERWISE SPECIFIED

REV. **DATE: 6/19/08** **C.N. NO. 98644**

DWG. NO. P-15561 **PRODUCT NO. Z125-103**