



Z1715-76

SPECIFICATION SHEET

ROOF DRAIN W/ PERFORATED EXTENSION, COVER AND AUXILIARY SIDE OUTLET

TAG _____

Dimensional Data (inches and [mm]) are Subject to Manufacturing Tolerances and Change Without Notice

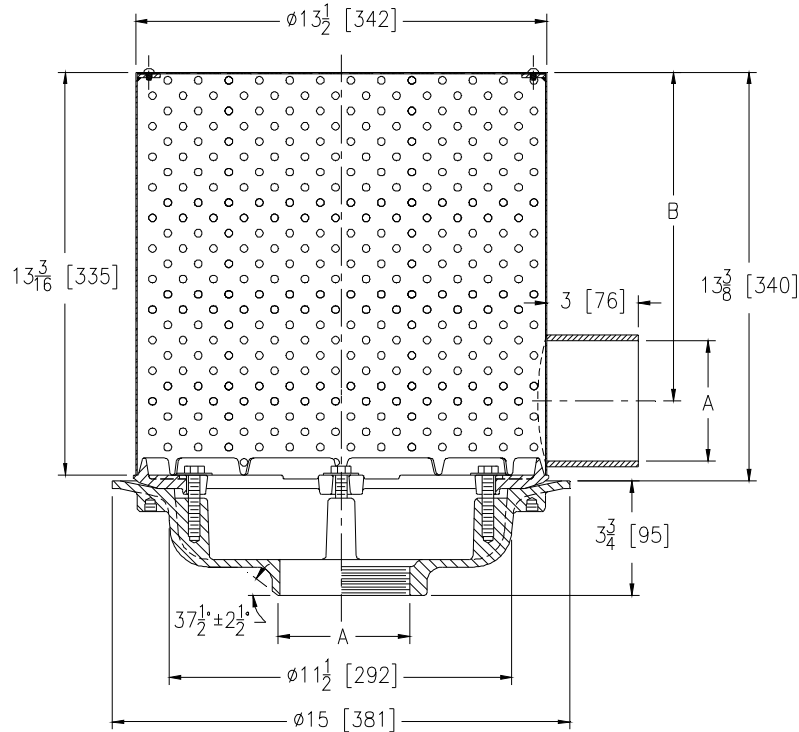

A-Pipe Size In. [mm]	B	Approx. Wt. Lbs [kg]	Cover Open Area Sq. In. [cm ²]
3-4 [76-102]	10 3/4 [273]	52 [24]	71 [458]
6 [152]	9 1/2 [241]	52 [24]	

ENGINEERING SPECIFICATION: ZURN Z1715-76

Type 304 (CF8) stainless steel roof drain body with galvanized cast iron combination gravel guard/flashing clamp, perforated extension and cover with auxiliary side outlet.

OPTIONS (Check/specify appropriate options)

PIPE SIZE

3-4-6 [76-102-152]

3-4 [76-102]

(Specify size/type) OUTLET

____ BW Butt-weld
(Specify Schedule 10, 40 or 80)
____ IP Threaded

PREFIXES

____ Z Type 304 (CF8) Stainless Steel Body*
____ ZC Type A-27 Carbon Steel Body (P.O.A.)
____ ZM Type 316 (CF8M) Stainless Steel Body

SUFFIXES

____ -C Galvanized Underdeck Clamp
____ -DP Top-Set® Deck Plate (Replaces both the -C and -R)
____ -E Galvanized Extension (Specify Height from 1 - 4 [25 - 102])
____ -R Galvanized Steel Sump Receiver
____ -VP Vandal-Proof Secured Top

*REGULARLY FURNISHED UNLESS OTHERWISE SPECIFIED

REV. DATE: 05/29/09 C.N. NO. 120036

DWG. NO. P-15715 PRODUCT NO. Z1715-76

ZURN INDUSTRIES, LLC. ♦ SPECIFICATION DRAINAGE OPERATION ♦ 1801 Pittsburgh Ave. ♦ Erie, PA 16514

Phone: 814/455-0921 ♦ Fax: 814/454-7929 ♦ World Wide Web: www.zurn.com

In Canada: ZURN INDUSTRIES LIMITED ♦ 3544 Nashua Drive ♦ Mississauga, Ontario L4V1L2 ♦ Phone: 905/405-8272 Fax: 905/405-1292