



# Z415S-102

## BODY ASSEMBLY W/ "TYPE S" STRAINER AND CLAW PROOF GRATE

SPECIFICATION SHEET

TAG \_\_\_\_\_

Dimensional Data (inches and [ mm ]) are Subject to Manufacturing Tolerances and Change Without Notice

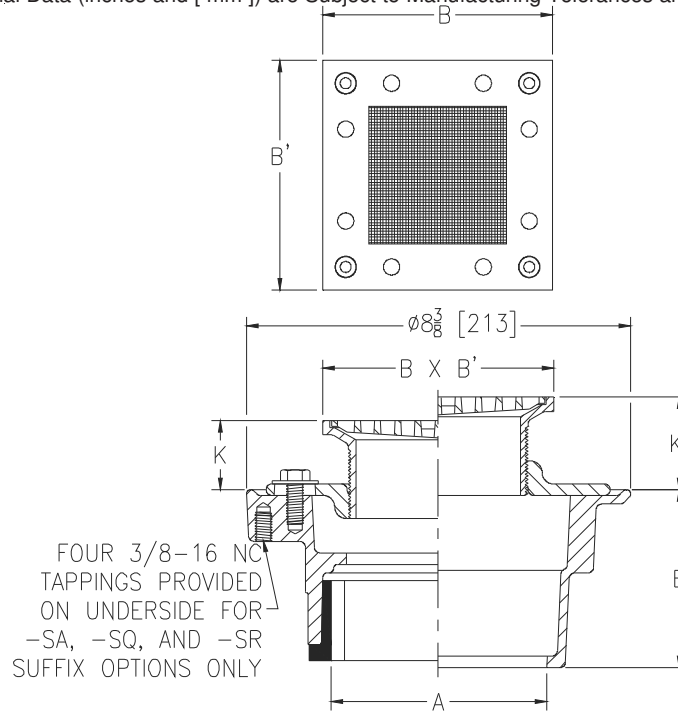

Dimensions in Inches [mm]						Approx. Wt. Lbs. [kg]	Strainer Open Area Sq. In. [cm <sup>2</sup> ]
A Pipe Size	B x B' Strainer Top Size	K		K'			
		Min.	Max.	Min.	Max.		
2,3,4 [51,76,102]	6 x 6 [152 x 152]	1-1/16 [27]	1-29/32 [48]	1-15/32 [37]	2-21/32 [67]	13 [6]	7 [43]

### ENGINEERING SPECIFICATION: ZURNZN415S-102

Floor and shower drain, Dura-Coated cast iron body with bottom outlet, combination invertible membrane clamp and adjustable collar with seepage slots and "TYPE S" polished nickel bronze, square heel-proof, light-duty strainer with claw proof mesh.

### OPTIONS (Check/specify appropriate options)

PIPE SIZE	(Specify size/type)	OUTLET	'E' BODY HT. DIM.
2,3,4 [51,76,102]	_____	IC Inside Caulk	4-3/16 [106]
2,3,4 [51,76,102]	_____	IG Inside Gasket	4-3/16 [106]
2 [51]	_____	IP Threaded	2-7/16 [62]
3 [76]	_____	IP Threaded	2-3/4 [70]
4 [102]	_____	IP Threaded	2-13/16 [71]
2,3,4 [51,76,102]	_____	NH No-Hub	3-13/16 [97]
2,3,4 [51,76,102]	_____	NL Neo-Loc	3-7/8 [98]

### PREFIXES

- \_\_\_\_\_ ZB D.C.C.I. Body Assembly w/ Polished Bronze Top
- \_\_\_\_\_ ZN D.C.C.I. Body Assembly w/ Polished Nickel Bronze Top\*

### SUFFIXES

- \_\_\_\_\_ -AR Acid Resisting Epoxy Coated Cast Iron
- \_\_\_\_\_ -EF 3/8 [10] Extension Frame
- \_\_\_\_\_ -G Galvanized Cast Iron
- \_\_\_\_\_ -P Trap Primer Connection (Specify 1/2 [13] or 3/4 [19])
- \_\_\_\_\_ -SA Stabilizer Assembly (See Z1035)
- \_\_\_\_\_ -SQ Stabilizer Q-Deck (See Z1035-Q)
- \_\_\_\_\_ -SR Stabilizer Ring
- \_\_\_\_\_ -TC Neo-Loc Test Cap Gasket (2 [51] - 4 [102] NL Outlet Only)
- \_\_\_\_\_ -U 1 - 3 [25 - 76] High Extension Adapter
- \_\_\_\_\_ -V Backwater Valve
- \_\_\_\_\_ -VP Vandal-Proof Secured Top
- \_\_\_\_\_ -18 Leveling Ring (See Z400-18)
- \_\_\_\_\_ -90 90° Threaded Side Outlet Body Assembly (2 [51], 3 [76] Only)

\* Regularly furnished unless otherwise specified.