



Z1172-170

SIZE 1200 LARGE CAPACITY GREASE INTERCEPTOR
W/15[381]RETRO-FIT EXTENSION

SPECIFICATION SHEET

TAG _____

Dimensional Data (inches and [mm]) are Subject to Manufacturing Tolerances and Change Without Notice

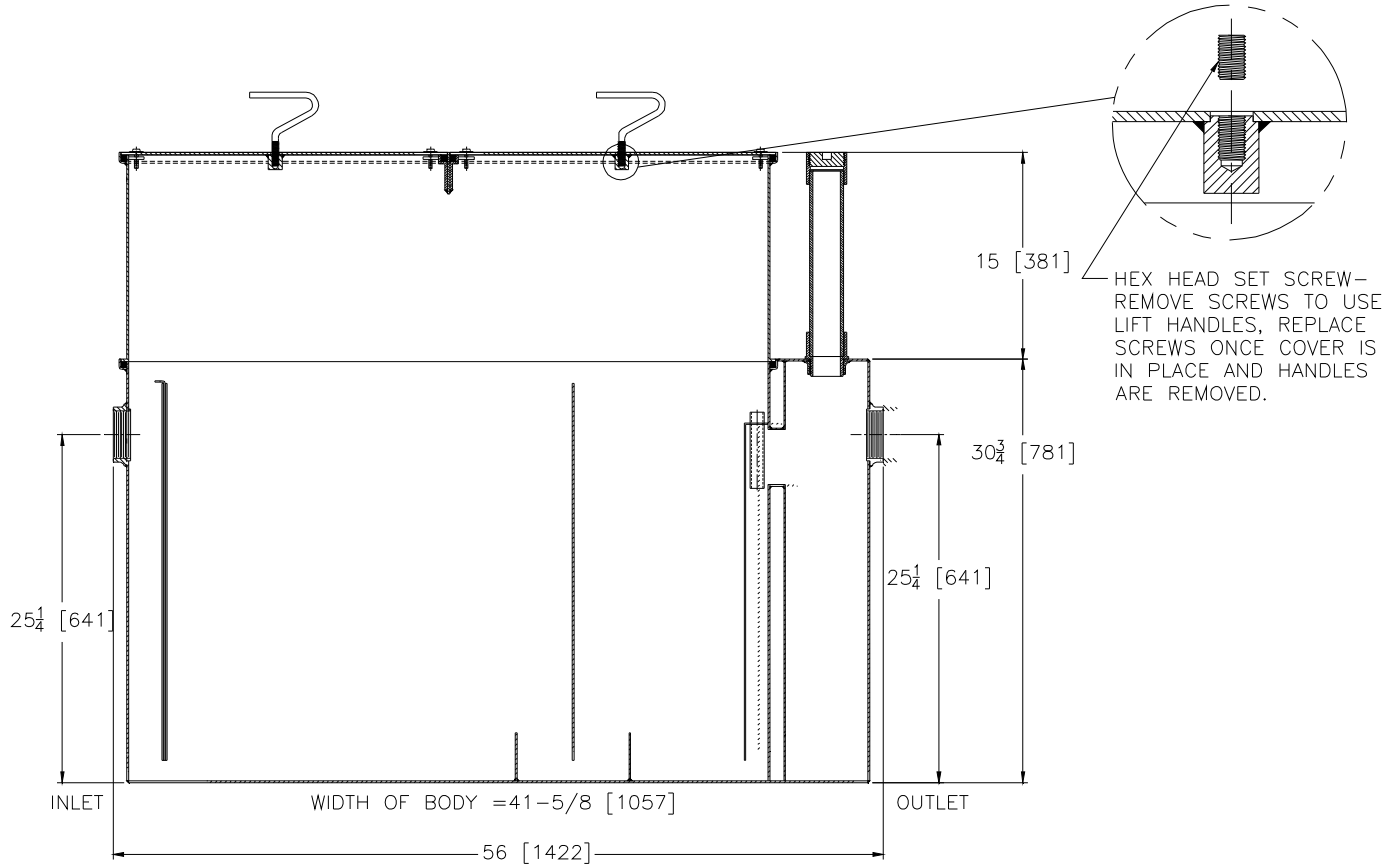

Size	Inlet/ Outlet Size	Flow Rate G.P.M. [L]	Capacity		No. of Covers	Approx. Wt. Lbs. [kg]
			Water Gal. [L]	Grease Lbs. [kg]		
1200	4 [102]	150 [567]	195 [737]	300 [136]	2	856 [389]

ENGINEERING SPECIFICATION: ZURN Z1172-170

Large capacity Acid Resistant Coated interior and exterior fabricated steel grease interceptor and extension, rated at 150 GPM and 300 Lbs. grease capacity, with internal air relief by-pass, bronze cleanout plug and visible double wall trap seal with removable pressure equalizing/flow diffusing baffle. Gasketed non-skid secured cover with removable lift handles, complete with flow control fitting. Regularly furnished with inlet and outlet in high position.

OPTIONS (Check/specify appropriate options)

PREFIXES

- ___ Z Acid Resistant Coated Fabricated Steel*
- ___ ZS All Type 304 Fabricated Stainless Steel

SUFFIXES

- ___ -AL Aluminum Cover
- ___ -K Anchor flange 1-3/4 [44] down from top and 2 [51] wide.
- ___ -KC Anchor flange 1-3/4 [44] down from top and 2 [51] wide with clamp collar.
- ___ -L Angle type (Z1108-L) flow control device.

* Regularly furnished unless otherwise specified.

Zurn Industries, LLC | Specification Drainage Operation
1801 Pittsburgh Avenue, Erie, PA U.S.A. 16502 · Ph. 855-663-9876, Fax 814-454-7929
In Canada | Zurn Industries Limited
3544 Nashua Drive, Mississauga, Ontario L4V 1L2 · Ph. 905-405-8272, Fax 905-405-1292
www.zurn.com

Rev. -
Date: 01/30/14
C.N. No. 130501
Prod. | Dwg. No. Z1172-170