



# Z1187-SI-153

## SIZE 350 SAND INTERCEPTOR WITH SOLID COVER AND VENT

SPECIFICATION SHEET

TAG \_\_\_\_\_

Dimensional Data (inches and [ mm ]) are Subject to Manufacturing Tolerances and Change Without Notice

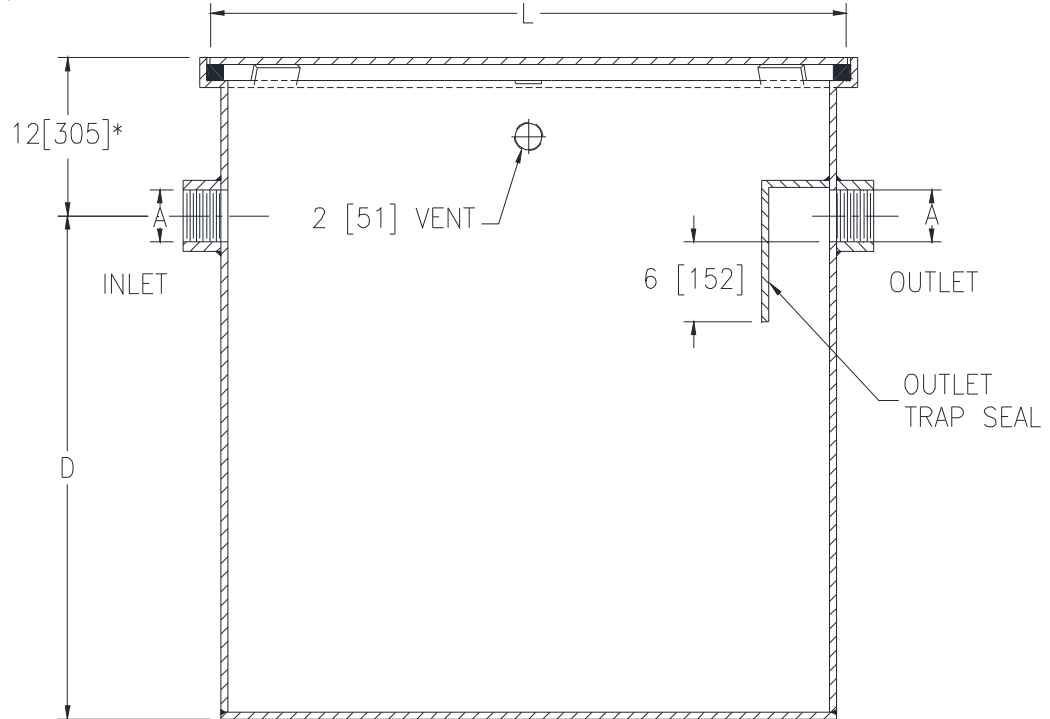

\*12[305] REGULARLY FURNISHED—  
SPECIFY DIMENSION IF HIGHER  
OR LOWER IS REQUIRED

Size	Max. Flow GPM [LPM]	Dimensions in Inches [mm]				Static Capacity Gal. [L]	Approx. Wt. Lbs. [kg]
		A Pipe Size	L	D	Width		
350	350 [1325]	6 [152]	84 [2134]	51 [1295]	48 [1219]	840 [3180]	1543 [700]

### ENGINEERING SPECIFICATION: ZURN Z1187-SI-153

Acid resistant coated interior and exterior fabricated steel sand interceptor with 2" vent, threaded inlet and outlet, complete with secured, gasketed, non-skid cover.

### OPTIONS (Check/specify appropriate options)

#### PREFIXES

\_\_\_ Z Acid Resistant Coated Fabricated Steel\*

#### SUFFIXES

- \_\_\_ -E Integral Extension Assembly (Specify extension height)
- \_\_\_ -DG Dureresist Grate
- \_\_\_ -K Anchor Flange 1-3/4 [44] down from top and 2 [51] wide. No extension required to accommodate -K option.
- \_\_\_ -KC Anchor Flange 1-3/4 [44] down from top and 2 [51] wide with clamp collar. No extension required to accommodate -KC option.
- \_\_\_ -NH No-Hub Inlet and Outlet (Z1040)
- \_\_\_ -SC Heavy-Duty Reinforced cover(s) rated at 10,000 ils. [4536 Kg.] maximum safe live load.
- \_\_\_ -VP Vandal-Proof Screws

\* Regularly furnished unless otherwise specified.