



Z100-304

15 [381] DIA. MAIN ROOF DRAIN W/ 2 1/2 [64]
HIGH STAINLESS STEEL PERFORATED DOME
AND EXTERNAL WATER DAM

SPECIFICATION SHEET

TAG _____

Dimensional Data (inches and [mm]) are Subject to Manufacturing Tolerances and Change Without Notice

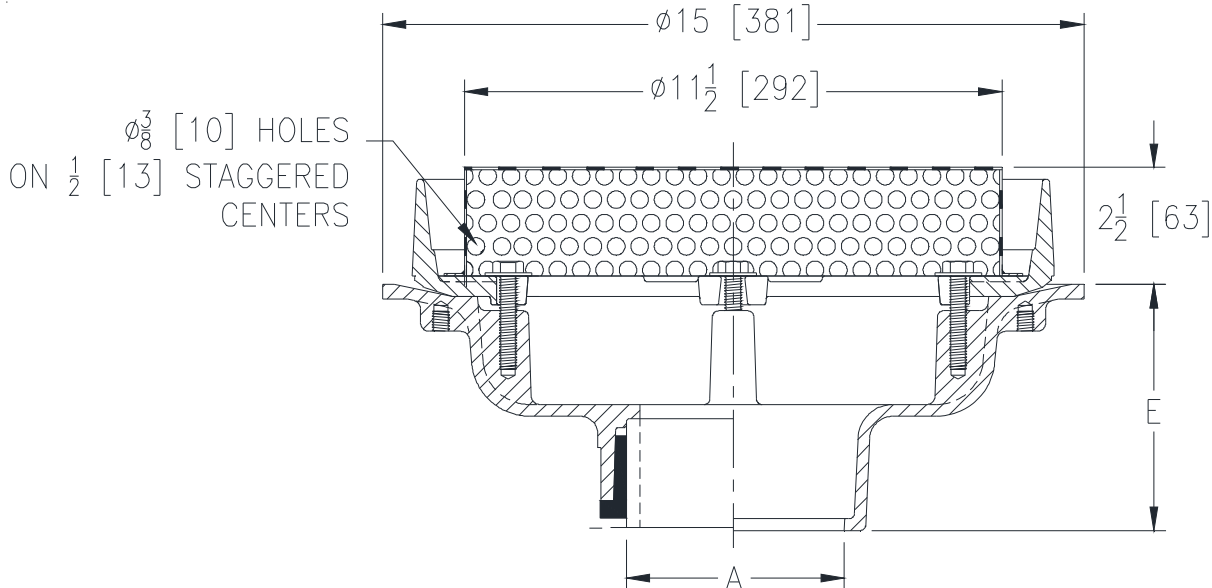

A Pipe Size In. [mm]	Approx. Wt. Lbs. [kg]	Dome Open Area Sq. In. [cm ²]
2,3,4 [51,76,102]	28 [13]	95 [613]
5,6 [127,152]	26 [12]	
8 [203]	29 [13]	

ENGINEERING SPECIFICATION: ZURN Z100-304

15" [381mm] Diameter roof drain. Dura-Coated cast iron body with 2" [51mm] high combination membrane flashing clamp/water dam and 2-1/2" [64mm] high stainless steel perforated dome with 3/8" [10mm] diameter holes.

OPTIONS (Check/specify appropriate options)

PIPE SIZE

- 2,3,4,5,6,8 [51,76,102,127,152,203]
- 2,3,4,5,6,8 [51,76,102,127,152,203]
- 2,3,4,5,6,8 [51,76,102,127,152,203]
- 2,3,4 [51,76,102]
- 6 [152]

(Specify size/type) **OUTLET**

- ___ IC Inside Caulk
- ___ IP Threaded
- ___ NH No-Hub
- ___ NL Neo-Loc
- ___ NL Neo-Loc

E BODY HT. DIM.

- 5-1/4 [133]
- 3-3/4 [95]
- 5-1/4 [133]
- 4-9/16 [116]
- 5-7/16 [112]

PREFIXES

- ___ ZS D.C.C.I. Body with Stainless Steel Perforated Dome*

SUFFIXES

- | | |
|---|---|
| ___ -AC Angular Underdeck Clamp | ___ -R Roof Sump Receiver |
| ___ -AR Acid Resistant Epoxy Coated | ___ -SC Secondary Clamp Collar |
| ___ -C Underdeck Clamp | ___ -SS Stainless Steel Mesh Screen Over Dome |
| ___ -DE Deck Extension | ___ -TC Neo-Loc Test Cap Gasket |
| ___ -DP Top-Set® Deck Plate (Replaces both the -C and -R) | (2,3,4 [51,76,102] NL Bottom Outlet Only) |
| ___ -DR Top-Set® Drain Riser | ___ -84 Stainless Steel Perforated Gravel Guard |
| ___ -DX Dex-o-tex Flange | ___ -85 Stainless Steel Perforated Extension |
| ___ -E Static Extension 1 [25] thru 4 [102] (Specify Ht.) | ___ -90 90° Threaded Side Outlet Body |
| ___ -EA Adjustable Extension Assembly | (2,3,4,6 [51,76,102,152]) |
| ___ -EB Top-Set® Adjustable Extension Assembly | |
| ___ -G Galvanized Cast Iron | |

* Regularly furnished unless otherwise specified.