



# Z107-C-85

20 [508] WIDE DECK FLANGE ROOF DRAIN W/  
UNDERDECK CLAMP & PERFORATED EXTENSION

SPECIFICATION SHEET

TAG \_\_\_\_\_

Dimensional Data (inches and [ mm ]) are Subject to Manufacturing Tolerances and Change Without Notice

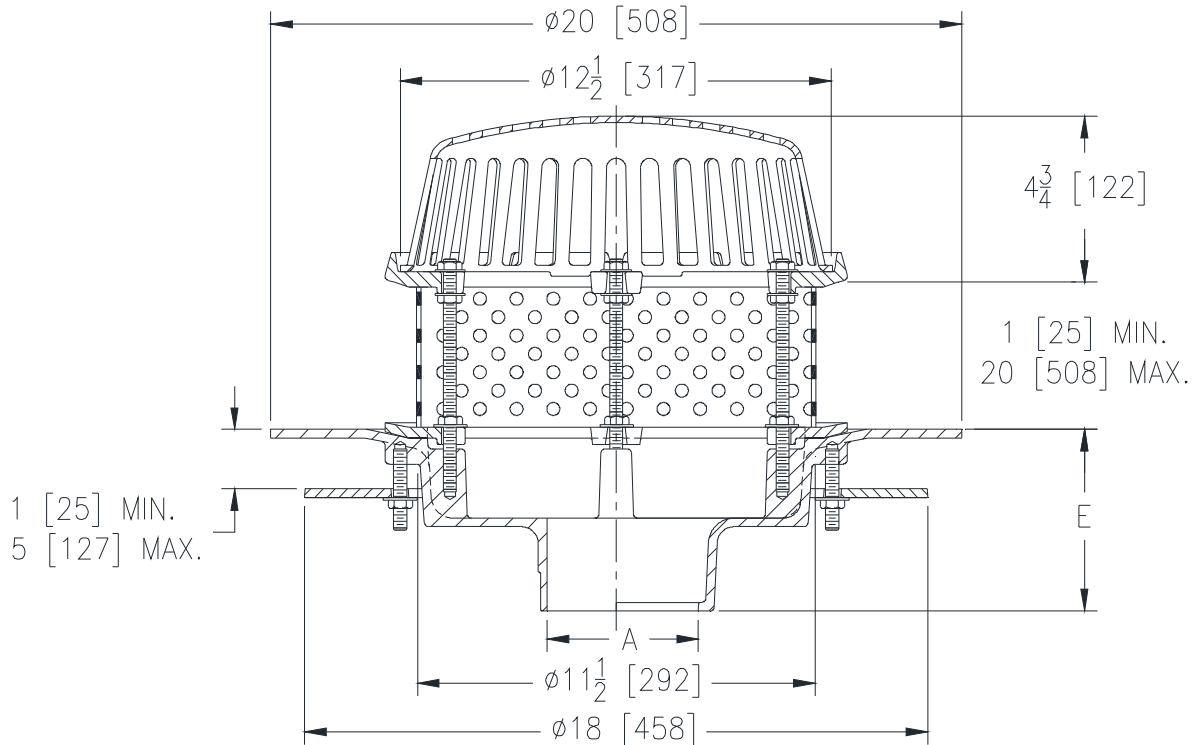

A Pipe Size In [mm]	Approx. Wt. Lbs. [kg]	Dome Open Area Sq. In. [cm <sup>2</sup> ]
3, 4 [76, 102]	52 [24]	103 [665]
6, 8 [152, 203]		

**ENGINEERING SPECIFICATION: ZURN Z107-C-85**  
20" [508mm] Diameter wide deck flange roof drain. Dura-Coated cast iron with combination membrane flashing clamp/gravel guard, underdeck clamp, stainless steel perforated extension and low silhouette Poly-Dome.

**OPTIONS** (Check/specify appropriate options)

**PIPE SIZE**

- 3,4,6 [76,102,152]
- 3,4 [76,102]
- 3,4,6,8 [76,102,152,203]

(Specify size/type) **OUTLET**

- \_\_\_\_\_ IC Inside Caulk
- \_\_\_\_\_ IP Threaded
- \_\_\_\_\_ NH No-Hub

**E BODY HT. DIM.**

- 5-1/4 [133]
- 5-1/4 [133]
- 5-1/4 [133]

**PREFIXES**

- \_\_\_ Z D.C.C.I. Body with Poly-Dome\*
- \_\_\_ ZA D.C.C.I. Body with Aluminum Dome
- \_\_\_ ZC D.C.C.I. Body with Cast Iron Dome

**SUFFIXES**

- \_\_\_ -AR Acid Resistant Epoxy Coated Finish
- \_\_\_ -E Static Extension 1 [25] thru 4 [102] (Specify Ht.)
- \_\_\_ -EA Adjustable Extension Assembly  
2-1/8 [54] thru 3-1/2 [89]
- \_\_\_ -FG Flush Grate
- \_\_\_ -G Galvanized Cast Iron
- \_\_\_ -SS Stainless Steel Mesh Screen Over Dome
- \_\_\_ -VP Vandal Proof Secured Top
- \_\_\_ -84 Stainless Steel Perforated Gravel Guard

\* Regularly furnished unless otherwise specified.