



ZN1902-K

12-3/8 x 12-3/8 [314 x 314] A.R.E. SANI-FLOR RECEPTOR
 10 [254] SUMP DEPTH W/ ANCHOR FLANGE &
 N.B. FRAME & GRATE

SPECIFICATION SHEET

TAG _____

Dimensional Data (inches and [mm]) are Subject to Manufacturing Tolerances and Change Without Notice

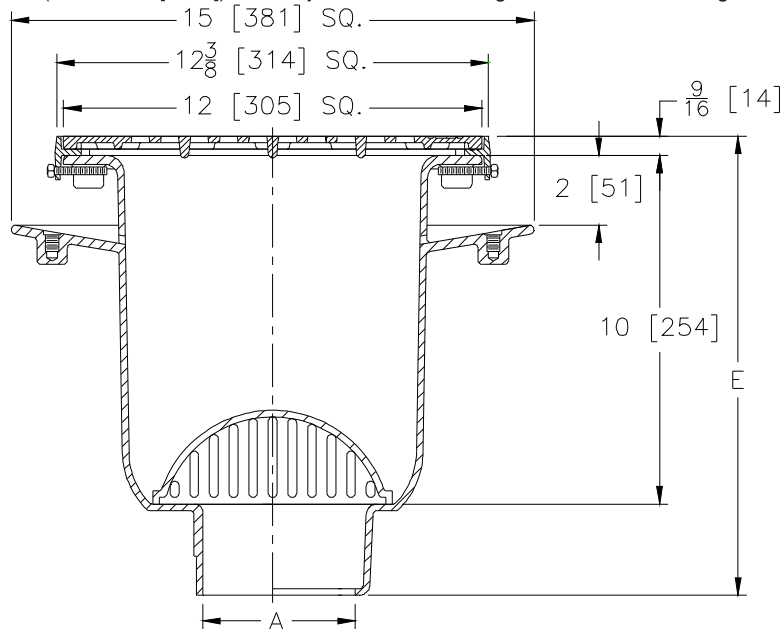

A - Pipe Size In. [mm]	Approx Wt. Lbs. [kg]	Grate Open Area Sq. In. [cm ²]
2, 3, 4 [51, 76, 102]	36 [16]	25 [161]

ENGINEERING SPECIFICATION: ZURN ZN1902-K

Sani-Flor Receptor 12-3/8" x 12-3/8" x 10" [314mm x 314mm x 254mm] deep cast iron body with anchor flange and seepage holes, white acid resisting porcelain enamel interior, black ground enamel exterior coating, nickel bronze frame and grate complete with white ABS anti-splash interior bottom dome strainer.

OPTIONS (Check/specify appropriate options)

PIPE SIZE

- 3, 4 [76, 102]
- 2, 3, 4 [51, 76, 102]
- 2, 3, 4 [51, 76, 102]

(Specify size/type) OUTLET

- _____ IC Inside Caulk
- _____ NH No-Hub
- _____ NL Neo-Loc

'E' BODY HT. DIMENSION

- 13-1/8 [333]
- 13-1/8 [333]
- 12-1/2 [317]

PREFIXES

___ ZN Cast Iron Body w/ White A.R.E. Interior, 12-3/8 [314] Square N.B. Frame & Full Grate w/ 1/2 [13] Square Openings.*

SUFFIXES

- | | |
|--|---|
| ___ -DX Dex-o-Tex Flange | ___ -15 Solid Loose Set Cover |
| ___ -HP Heel-Proof Grate | ___ -19 Full Hinged Grate |
| ___ -P 1/2 [13] Trap Primer Connection (See Z1023) | ___ -23 Aluminum Bucket |
| ___ -SA Stabilizer Assembly (See Z1903) | ___ -25 White A.R.C. Bucket |
| ___ -TC Neo-Loc Test Cap Gasket
(2, 3, 4 [51, 76, 102] NL Bottom Outlet Only) | ___ -31 Stainless Steel Mesh Liner for Bucket |
| ___ -VPS Vandal-Proof Strainer | ___ -32 Aluminum Dome Strainer |
| ___ -1 (Less) Grate | ___ -33 White A.R.C. Anti-Splash Bottom Dome Strainer |
| ___ -2 1/2 Grate | |
| ___ -3 3/4 Grate | |
| ___ -4 Full Grate w/ Center Opening 3-1/32 [77] Square | |
| ___ -6 Grate w/ 6 [152] Dia. x 6 [152] High Funnel | |
| ___ -8 Grate w/ 8-7/8 x 3-5/8 x 3-3/4 [225 x 92 x 95]
High Oval Funnel | |
| ___ -11 Vandal-Proof Secured Grate | |

* Regularly furnished unless otherwise specified.

Zurn Industries, LLC | Specification Drainage Operation
 1801 Pittsburgh Avenue, Erie, PA U.S.A. 16502 · Ph. 855-663-9876, Fax 814-454-7929
 In Canada | Zurn Industries Limited
 3544 Nashua Drive, Mississauga, Ontario L4V 1L2 · Ph. 905-405-8272, Fax 905-405-1292
www.zurn.com

Rev. C
 Date: 10/13/2017
 C.N. No. 138788
 Prod. | Dwg. No. ZN1902-K