



# Z154-DT

12-5/8 [321] SQUARE TOP PROM-DECK DRAIN  
W/ DECORATIVE GRATE & ROTATABLE FRAME

SPECIFICATION SHEET

TAG \_\_\_\_\_

Dimensional Data (inches and [ mm ]) are Subject to Manufacturing Tolerances and Change Without Notice

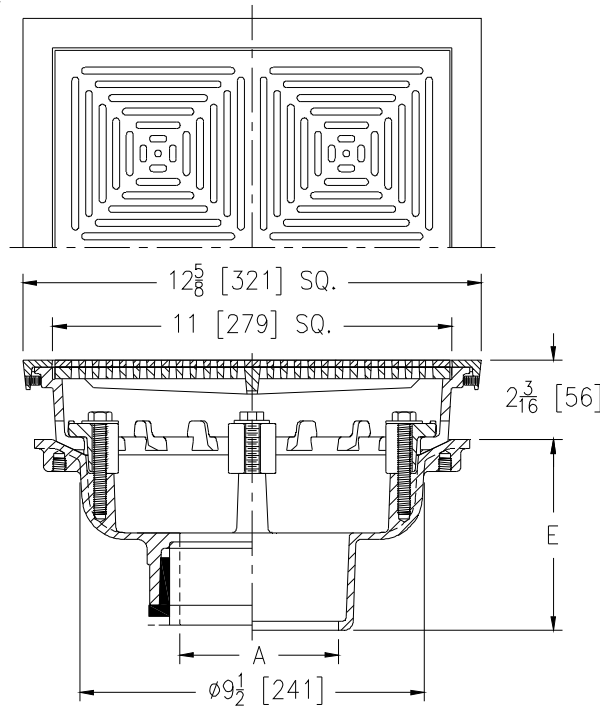

A Pipe Size In. [mm]	Approx. Wt. Lbs. [kg]	Grate Open Area Sq. In. [cm <sup>2</sup> ]
2,3,4,6 [51,76,102,152]	34 [15]	42 [271]

### ENGINEERING SPECIFICATION: ZURNZN154-DT

12-5/8" [321mm] Square top Prom-Deck drain, Dura-Coated cast iron body with rotatable square promenade frame with seepage openings, frame clamps and decorative light duty heel-proof grate with 3/16" [5mm] wide slots and nickel bronze veneer frame and grate.

### OPTIONS (Check/specify appropriate options)

#### PIPE SIZE

2, 3, 4, 6 [51, 76, 102, 152]  
2, 3, 4, 6 [51, 76, 102, 152]  
2, 3, 4, 6 [51, 76, 102, 152]  
2, 3, 4 [51, 76, 102]

#### (Specify size/type) OUTLET

\_\_\_ IC Inside Caulk  
\_\_\_ IP Threaded  
\_\_\_ NH No-Hub  
\_\_\_ NL Neo-Loc

#### 'E' BODY HT. DIM.

5-1/4 [133]  
3-3/4 [95]  
5-1/4 [133]  
4-9/16 [117]

### PREFIXES

\_\_\_ Z D.C.C.I. Body with Top (Subtract 3/16 [5] to 2 [51] Dim. & 5/8 [16] to 12 [305] Dim.)  
\_\_\_ ZB D.C.C.I. Body with Decorative Polished Bronze Top  
\_\_\_ ZN D.C.C.I. Body with Decorative Polished Nickel Bronze Top\*

### SUFFIXES

___ -AR Acid Resistant Epoxy Coated Finish	___ -SC Secondary Clamp Collar
___ -C Underdeck Clamp	___ -TC Neo-Loc Test Cap Gasket (2,3,4 [51,76,102] NL Bottom Outlet Only)
___ -DP Top-Set® Roof Deck Plate	___ -TS Top Secured with Slotted Screws
___ -E Static Extension (1 [25] thru 4 [102](Specify Height))	___ -VP Vandal-Proof Secured Top
___ -EB Top-Set® Adjustable Extension Assembly	___ -Y Sediment Bucket
___ -G Galvanized Cast Iron	___ -85 Stainless Steel Perforated Extension
___ -S Secondary Strainer	___ -90 90° Threaded Side Outlet Body (2,3,4 [51,76,102])

\* Regularly furnished unless otherwise specified.

Zurn Industries, LLC | Specification Drainage Operation  
1801 Pittsburgh Avenue, Erie, PA U.S.A. 16502 · Ph. 855-663-9876, Fax 814-454-7929  
In Canada | Zurn Industries Limited  
3544 Nashua Drive, Mississauga, Ontario L4V 1L2 · Ph. 905-405-8272, Fax 905-405-1292  
[www.zurn.com](http://www.zurn.com)

Rev. F  
Date: 7/05/2018  
C.N. No. 140271  
Prod. | Dwg. No. Z154-DT