



Z1188-ST-104

LARGE CAPACITY OIL INTERCEPTOR WITH INTEGRAL
271 GALLON STORAGE TANK AND 4 [102] HIGH INLET/OUTLET

SPECIFICATION SHEET

TAG _____

Dimensional Data (inches and [mm]) are Subject to Manufacturing Tolerances and Change Without Notice

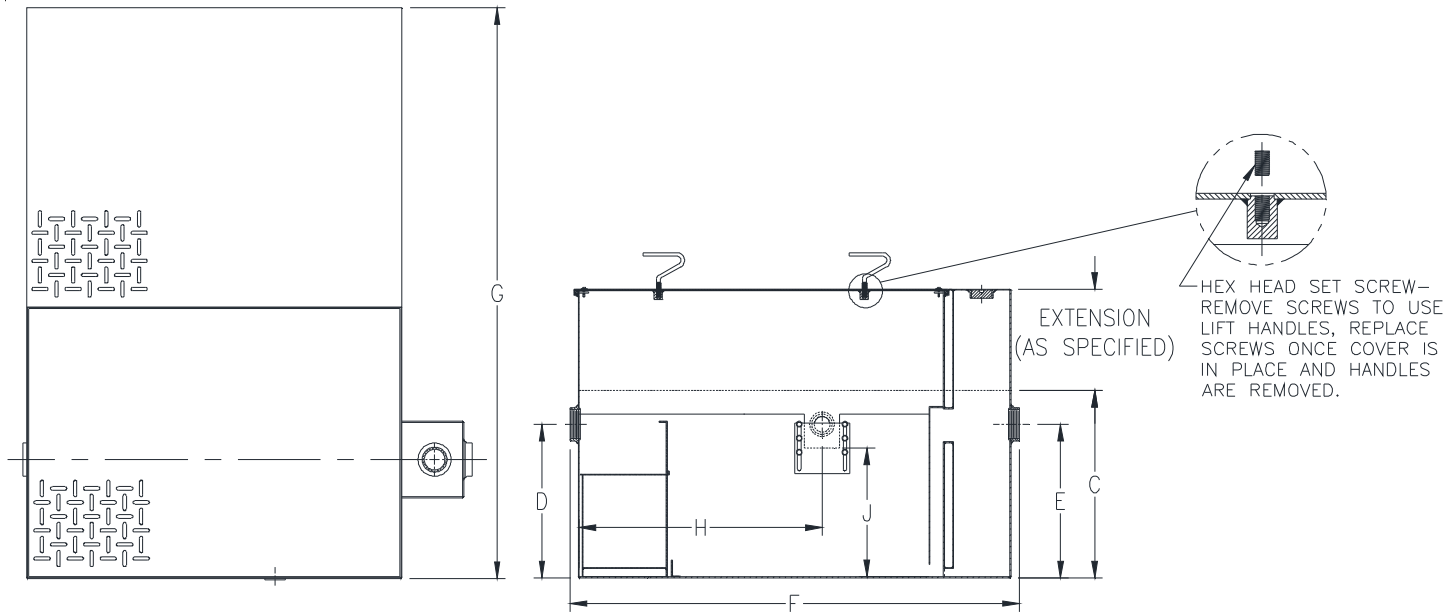

| Flow Rate GPM [LPM] | Oil Storage Tank Cap. Gal. [L] | Inlet/Outlet Size In [mm] | No. of Covers | |
|------------------------|--------------------------------------|------------------------------|---------------|------|
| | | | Trap | Tank |
| 100 [379] | 271 [1026] | 4 [102] | 1 | 1 |

| Flow Rate GPM [LPM] | Water Capacity Gal. [L] | Approx. Wt. Lbs. [kg] | Dimensions in Inches [mm] | | | | | |
|------------------------|-------------------------------|--------------------------|---------------------------|----------|---------------|---------------|--------------|--------------|
| | | | C | D/E | F | G | H | J |
| 100 [379] | 159 [602] | 2650 [1202] | 27 [686] | 23 [584] | 60-3/8 [1534] | 47-1/4 [1200] | 35-1/4 [895] | 19-3/4 [502] |

ENGINEERING SPECIFICATION: ZURN Z1188-ST-104

Acid Resistant Coated interior and exterior fabricated steel oil interceptor. Complete with bronze cleanout plug and visible double wall trap seal, removable combination pressure equalizing/flow diffusing baffle and sediment bucket, oil draw-off, vent connections, secured gasketed non-skid cover, flow control fitting and left hand integral storage tank. Regularly furnished with 4" [102mm] high inlet and outlet. Note: location of outlet from bottom of interceptor cannot be changed.

OPTIONS (Check/specify appropriate options)

PREFIXES

___ Z Acid Resistant Coated Fabricated Steel*

SUFFIXES

- ___ -E Integral Acid Resistant Coated interior and exterior fabricated steel extension section. (Specify 'C' Dim. required) for recessed installation.
- ___ -HD Heavy-duty traffic cover rated at 10,000 lbs. [454 kg] maximum safe live load. An increased 'C' dim. is required when -HD option is specified. (See -HD option specification sheet)
- ___ -K Anchor flange 1-3/4 [44] down from top and 2 [51] wide. A 3 [76] minimum extension height is required when anchor flange (-K) option is specified. (Specify 'C' Dim. height required.)
- ___ -KC Anchor flange 1-3/4 [44] down from top and 2 [51] wide with clamp collar.
- ___ -STR Storage tank on right hand side when facing the inlet.

* Regularly furnished unless otherwise specified.