



Z100-291

15 [381] DIAMETER MAIN ROOF DRAIN W/ PERFORATED STANDPIPE, GRAVEL GUARD, & STABILIZER ASSEMBLY

TAG _____

Dimensional Data (inches and [mm]) are Subject to Manufacturing Tolerances and Change Without Notice

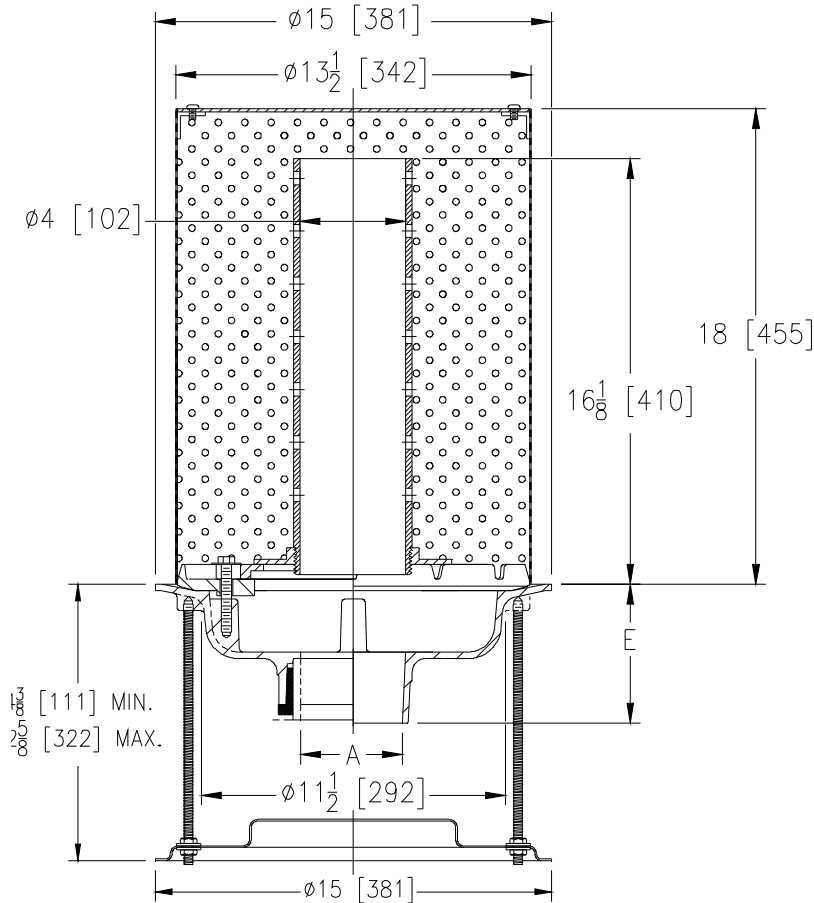

A Pipe Size In.	Approx. Wt. Lbs. [kg]
2-3-4 [51-76-102]	36 [16]

ENGINEERING SPECIFICATION: ZURN Z100-291

15 [381] Diameter roof drain. Dura-Coated cast iron body with combination membrane flashing clamp/gravel guard, 4 [102] standpipe, stainless steel perforated gravel guard with solid secured top, and stabilizer assembly.

OPTIONS (Check/specify appropriate options)

PIPE SIZE

- 2-3-4 [51-76-102]
- 2-3-4 [51-76-102]

(Specify size/type) OUTLET

- _____ NH No-Hub
- _____ NL Neo-Loc

E BODY HT. DIM.

- 5-1/4 [133]
- 4-9/16 [116]

PREFIXES

- _____ Z D.C.C.I. Body

SUFFIXES

- _____ -AR Acid Resistant Epoxy Coated
- _____ -DX Dex-o-tex Flange
- _____ -E Static Extension 1 [25] thru 4 [102] (Specify Ht.)
- _____ -G Galvanized Cast Iron
- _____ -R Roof Sump Receiver
- _____ -SC Secondary Clamp Collar
- _____ -VP Vandal-Proof Secured Top

* Regularly furnished unless otherwise specified.