



# Z100-326

15 [381] DIAMETER MAIN ROOF DRAIN WITH  
FLUSH GRATE & 39 [991] PERFORATED EXTENSION

SPECIFICATION SHEET

TAG \_\_\_\_\_

Dimensional Data (inches and [ mm ]) are Subject to Manufacturing Tolerances and Change Without Notice

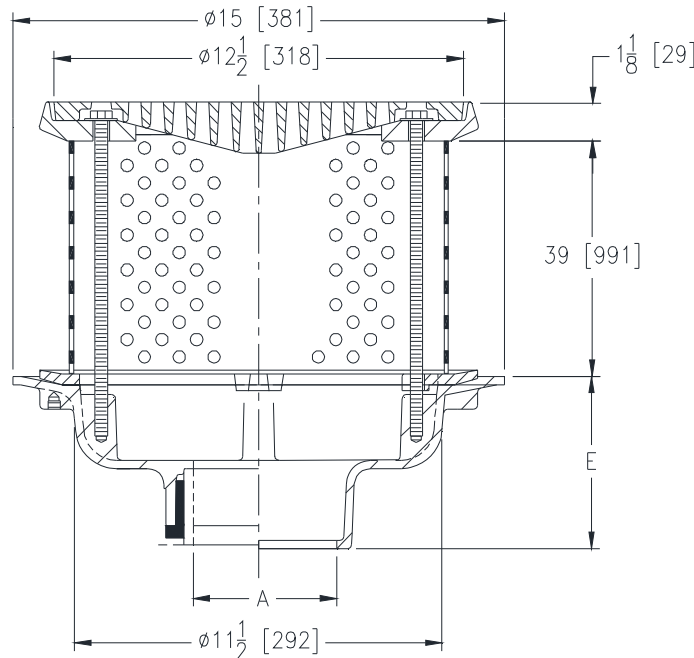

A Pipe Size In. [mm]	Approx. Wt. Lbs. [kg]	Grate Open Area Sq. In. [cm <sup>2</sup> ]
2,3,4 [51,76,102]	28 [13]	32 [206]
5,6 [127,152]	29 [13]	
8 [203]	30 [14]	

**ENGINEERING SPECIFICATION: ZURN Z100-326**

15" [381mm] Diameter roof drain. Dura-Coated cast iron body with combination membrane flashing clamp/gravel guard, 39" [991mm] perforated extension, secondary clamp collar, and flush grate.

**OPTIONS** (Check/specify appropriate options)

**PIPE SIZE**

- 2,3,4,5,6,8 [51,76,102,127,152,203]
- 2,3,4,5,6,8 [51,76,102,127,152,203]
- 2,3,4,5,6,8 [51,76,102,127,152,203]
- 2,3,4 [51,76,102]
- 6 [152]

(Specify size/type) **OUTLET**

- \_\_\_\_\_ IC Inside Caulk
- \_\_\_\_\_ IP Threaded
- \_\_\_\_\_ NH No-Hub
- \_\_\_\_\_ NL Neo-Loc
- \_\_\_\_\_ NL Neo-Loc

**E BODY HT. DIM.**

- 5-1/4 [133]
- 3-3/4 [95]
- 5-1/4 [133]
- 4-9/16 [116]
- 5-7/16 [138]

**PREFIXES**

- \_\_\_\_\_ Z D.C.C.I. Body and Grate\*

**SUFFIXES**

- |  |   |
|--|---|
| _____ -AC Angular Underdeck Clamp                                  | _____ -EB Top-Set® Adjustable Extension Assembly                            |
| _____ -AR Acid Resistant Epoxy Coated Finish                       | _____ -G Galvanized Cast Iron   |
| _____ -C Underdeck Clamp   | _____ -R Roof Sump Receiver   |
| _____ -DE Deck Extension   | _____ -TC Neo-Loc Test Cap Gasket (2,3,4 [51,76,102] NL Bottom Outlet Only) |
| _____ -DP Top-Set® Deck Plate (Replaces Both The -C and -R)        | _____ -TS Top Secured With Slotted Screws                                   |
| _____ -DR Top-Set® Drain Riser                                     | _____ -VP Vandal Proof Secured Top  |
| _____ -DX Dex-o-Tex Flange   | _____ -90 90° Threaded Side Outlet Body                                     |
| _____ -E Static Extension 1 [25] thru 4 [102] (Specify Ht.)        |   |
| _____ -EA Adjustable Extension Assembly 2-1/8 [54] thru 3-1/2 [89] |   |

\* Regularly furnished unless otherwise specified.