



Z566-87

13 1/4 [337] X 12 3/4 [324] TOP DRAIN W/ VENEER FRAME & 3/4 GRATE, AND BOT- TOM DOME STRAINER

SPECIFICATION SHEET

TAG _____

Dimensional Data (inches and [mm]) are Subject to Manufacturing Tolerances and Change Without Notice

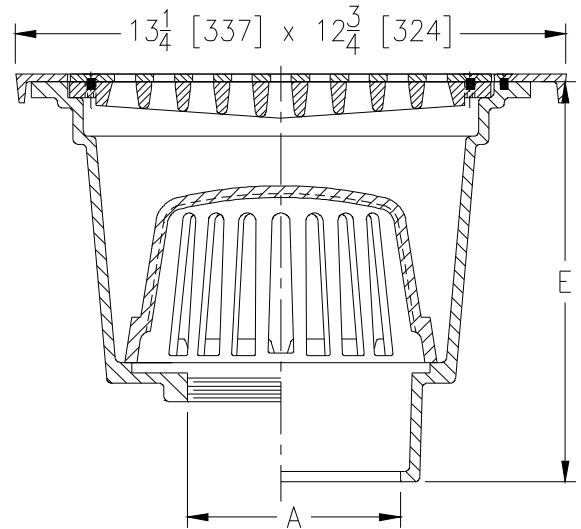
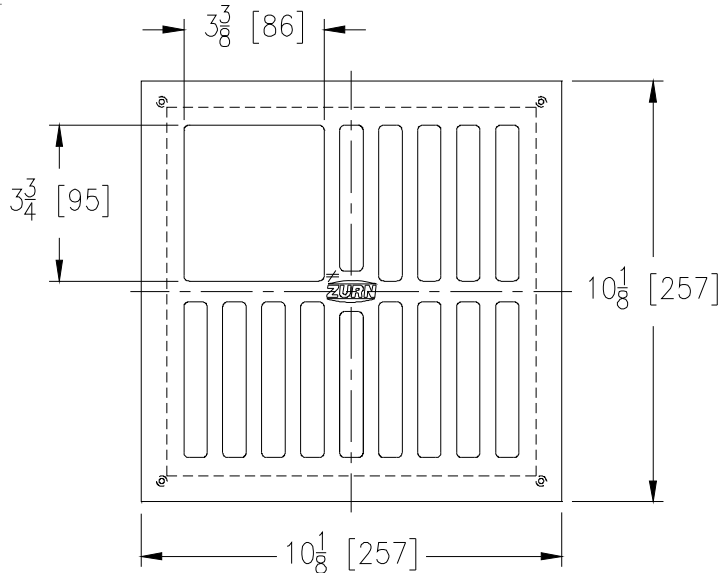

A - Pipe Size Inches	Approx. Wt. Lbs. [kg]	Grate Open Area Sq. In. [cm ²]
2-3-4 [51-76-102]	50 [23]	42 [270]

ENGINEERING SPECIFICATION: ZURN Z566-87

12 [305] Square top drain, Dura-Coated cast iron body with bottom outlet, loose set cast iron dome strainer, and 3/4 cast iron grate with nickel bronze veneer.

OPTIONS (Check/specify appropriate options)

PIPE SIZE

- 2, 3, 4 [51, 76, 102]
- 2, 3, 4 [51, 76, 102]
- 3, 4 [76, 102]
- 2, 3, 4 [51, 76, 102]

(Specify size/type) OUTLET

- _____ IC Inside Caulk
- _____ IG Inside Caulk w/Sealtrol Gskt.
- _____ IP Threaded
- _____ NL Neo-Loc

'E' BODY HT. DIM.

- 9 5/8 [244]
- 9 5/8 [244]
- 7 5/8 [194]
- 9 [229]

PREFIXES

- _____ ZB D.C.C.I. Body with Polished Bronze Top (Add 3/16 [5] to 'E' Dim.)
- _____ ZN D.C.C.I. Body with Polished Nickel Bronze Top (Add 3/16 [5] to 'E' Dim.) *

SUFFIXES

- _____ -AR Acid Resisting Epoxy Coated Cast Iron
- _____ -G Galvanized Cast Iron
- _____ -TC Neo-Loc Test Cap Gasket
(2 [51] - 4 [102] NL Bottom Outlet Only)

REV.	DATE: 1/25/11	C.N. NO. 120799
DWG. NO. 304185	PRODUCT NO. Z566-87	

*REGULARLY FURNISHED UNLESS OTHERWISE SPECIFIED

ZURN INDUSTRIES, LLC. ♦ SPECIFICATION DRAINAGE OPERATION ♦ 1801 Pittsburgh Ave. ♦ Erie, PA 16514

Phone: 814/455-0921 ♦ Fax: 814/454-7929 ♦ World Wide Web: www.zurn.com

In Canada: ZURN INDUSTRIES LIMITED ♦ 3544 Nashua Drive ♦ Mississauga, Ontario L4V1L2 ♦ Phone: 905/405-8272 Fax: 905/405-1292