



# Z541-124

SPECIFICATION SHEET

## 12 [305] DIAMETER HEAVY-DUTY DRAIN W/TOP-SET® DECK PLATE & ADJUSTABLE EXTENSION

TAG \_\_\_\_\_

Dimensional Data (inches and [ mm ]) are Subject to Manufacturing Tolerances and Change Without Notice

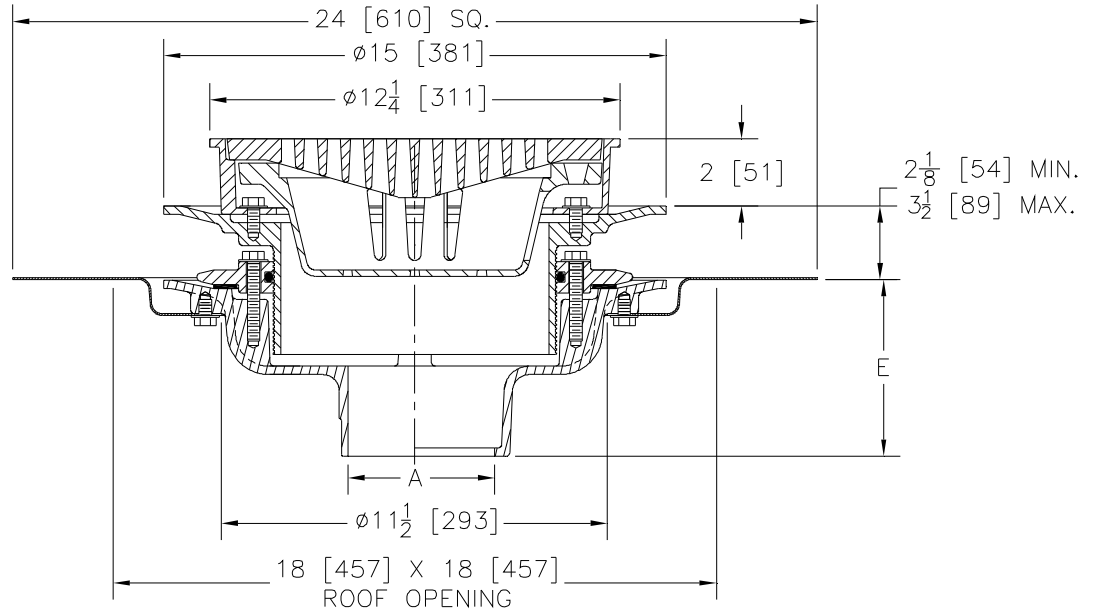

A- Pipe Size In.	Approx. Wt. Lbs. [kg]	Grate Open Area Sq. In. [cm <sup>2</sup> ]
2-3-4-5-6 [51-76-102-127-152]	70 [32]	29 [187]
8-10 [203-254]	72 [33]	

### ENGINEERING SPECIFICATION: ZURN Z541-124

12 [305] Diameter top drain. Dura-Coated cast iron body with bottom outlet, top-set® deck plate, seepage pan and combination membrane flashing clamp frame with adjustable extension for anti-tilt heavy-duty slotted grate with suspended sediment bucket.

### OPTIONS (Check/specify appropriate options)

#### PIPE SIZE

2 thru 6, 8, 10 [51 thru 152, 203, 254]  
 2 thru 6, 8, 10 [51 thru 152, 203, 254]  
 2 thru 6, 8, 10 [51 thru 152, 203, 254]  
 2 thru 6, 8, 10 [51 thru 152, 203, 254]  
 2 thru 4 [51 thru 102]

#### (Specify size/type) OUTLET

\_\_\_ IC Inside Caulk  
 \_\_\_ IG Inside Caulk w/Sealtrol Gskt.  
 \_\_\_ IP Threaded  
 \_\_\_ NH No-Hub  
 \_\_\_ NL Neo-Loc

#### 'E' BODY HT. DIM.

5 1/4 [133]  
 5 1/4 [133]  
 3 3/4 [95]  
 5 1/4 [133]  
 4 5/8 [117]

#### PREFIXES

\_\_\_ Z D.C.C.I. Body and Top\*  
 \_\_\_ ZB D.C.C.I. Body with Polished Bronze Top (Add 3/16 [5] to 2 [51] Dim.)  
 \_\_\_ ZN D.C.C.I. Body with Polished Nickel Bronze Top (Add 3/16 [5] to 2 [51] Dim.)

#### SUFFIXES

___ -AR Acid Resisting Epoxy Coated Cast Iron	___ -SS Stainless Mesh Liner for Bucket
___ -D Dome Grate (D.C.C.I. only)	___ -TC Neo-Loc Test Cap Gasket (2 [51] - 4 [102] NL Bottom Outlet Only)
___ -DG Duresist Grate	___ -TG Tractor Grate
___ -DX Dex-o-tex Flange	___ -TS Top Secured with Slotted Screws
___ -G Galvanized Cast Iron	___ -V Backwater Valve (See Z1099)
___ -H Hinged Grate	___ -VP Vandal-Proof Secured Top
___ -HP Heel-Proof Grate	___ -WS Wide Slotted Grate (50 sq, in open)
___ -LY (Less) Sediment Bucket	___ -90 90° Threaded Side Outlet Body (2 thru 6 [50 thru 150])
___ -P Trap Primer Connection	
___ -PH Packing House Grate	
___ -S Secondary Strainer	

REV.	DATE: 07/28/08	C.N. NO. 98922
DWG. NO. P-15578 PRODUCT NO. Z541-124		

\*REGULARLY FURNISHED UNLESS OTHERWISE SPECIFIED