



Z107-FG-85

20 [508] WIDE DECK FLANGE ROOF DRAIN
WITH PERFORATED EXTENSION & FLUSH GRATE

SPECIFICATION SHEET

TAG _____

Dimensional Data (inches and [mm]) are Subject to Manufacturing Tolerances and Change Without Notice

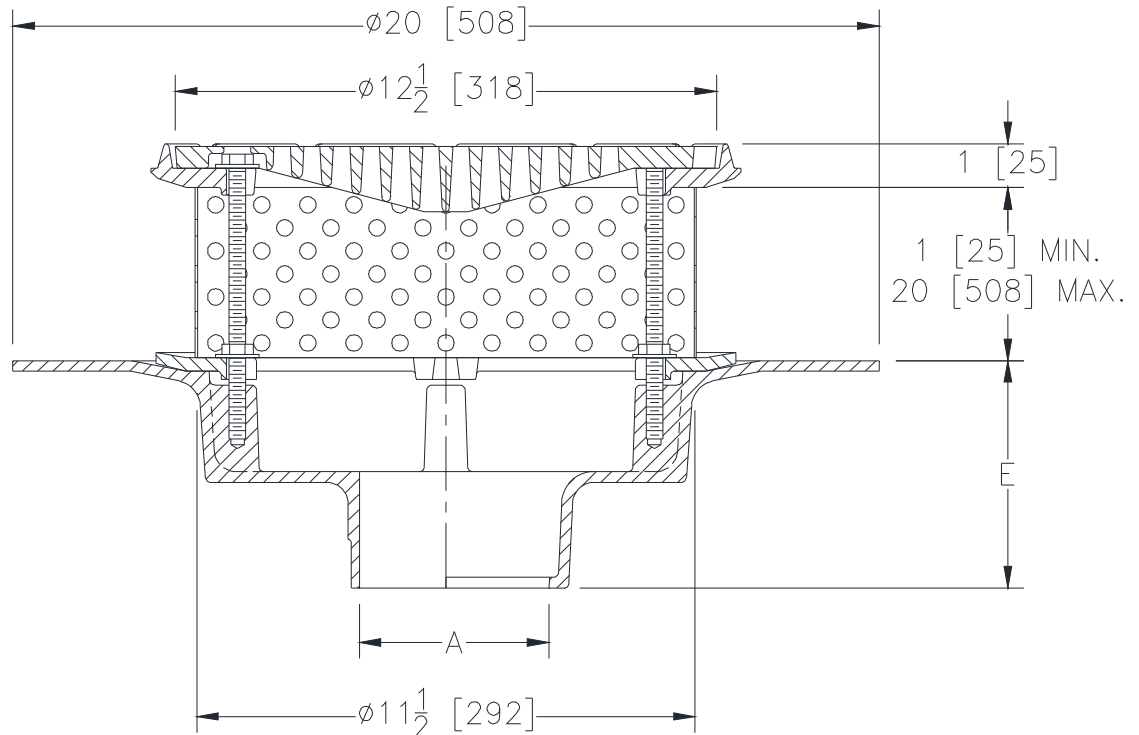

A Pipe Size In [mm]	Approx. Wt. Lbs. [kg]	Grate Open Area Sq. In. [cm ²]
3,4 [76,102]	41 [19]	30 [194]
6,8 [152,203]		

ENGINEERING SPECIFICATION: ZURN Z107-FG-85

20" [508mm] Diameter wide deck flange roof drain. Dura-Coated cast iron body with combination membrane flashing clamp/gravel guard, secondary clamp collar, stainless steel perforated extension and flush grate.

OPTIONS (Check/specify appropriate options)

PIPE SIZE

- 3,4,6 [76,102,152]
- 3,4 [76,102]
- 3,4,6,8 [76,102,152,203]

(Specify size/type) **OUTLET**

- _____ IC Inside Caulk
- _____ IP Threaded
- _____ NH No-Hub

E BODY HT. DIM.

- 5-1/4 [133]
- 5-1/4 [133]
- 5-1/4 [133]

PREFIXES

- ___ Z D.C.C.I. Body with Grate*

SUFFIXES

- ___ -AC Angular Underdeck Clamp
- ___ -AR Acid Resistant Epoxy Coated Finish
- ___ -C Underdeck Clamp
- ___ -E Static Extension 1 [25] thru 4 [102] (Specify Ht.)
- ___ -EA Adjustable Extension Assembly
2-1/8 [54] thru 3-1/2 [89]
- ___ -G Galvanized Cast Iron
- ___ -VP Vandal Proof Secured Top
- ___ -84 Stainless Steel Perforated Gravel Guard

* Regularly furnished unless otherwise specified.