



Z453B-C

DEEP SEAL TRAP DRAIN W/ "TYPE B" STRAINER AND CLAMP COLLAR

SPECIFICATION SHEET

TAG _____

Dimensional Data (inches and [mm]) are Subject to Manufacturing Tolerances and Change Without Notice

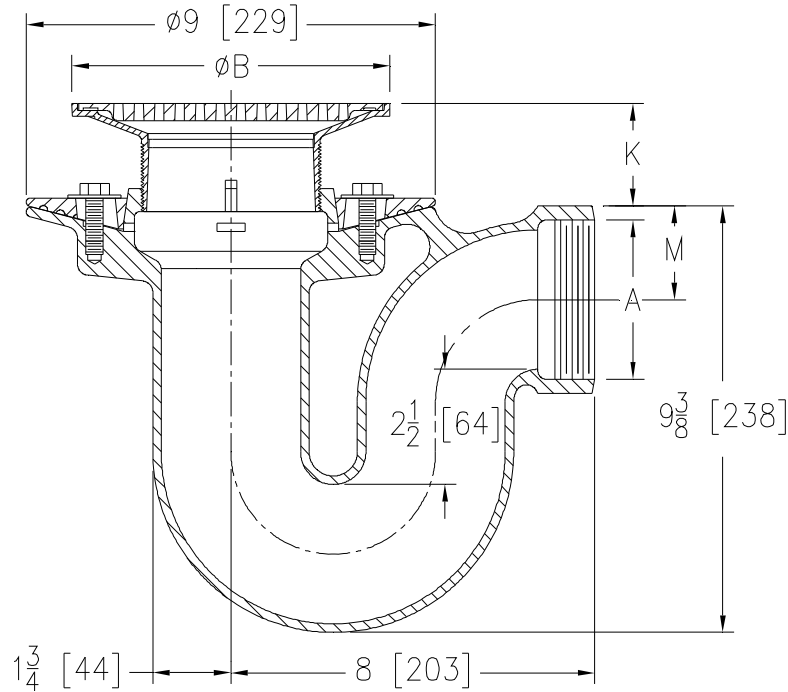

Dimensions In Inches [mm]					Approx. Wt. Lbs. [kg]	Strainer Open Area Sq. In. [cm ²]
A Pipe Size	B Strainer Dia.	K		M		
		Min.	Max.			
2, 3 [51, 76] 4 [102]	5 [127]	3/4 [19]	1-7/8 [48]	2-1/8 [54]	30 [14]	8 [52]
2, 3 [51, 76] 4 [102]	6 [152]	1-1/8 [29]	2-1/8 [54]	2-1/8 [54]	31 [14] 32 [15]	9 [58]
2, 3 [51, 76] 4 [102]	7 [178]	1-3/8 [35]	2-1/2 [64]	2-1/8 [54]	33 [15]	12 [77]
4 [102]	8 [203]	1-3/8 [35]	2-1/2 [64]	2-3/4 [70]	33 [15]	18 [116]

ENGINEERING SPECIFICATION:

ZURNZN453B-C

Deep Seal trap floor and shower drain, Dura-Coated cast iron body with uniform diameter integral trap, clamp collar, side outlet, seepage pan, and adjustable "TYPE B" polished, nickel bronze strainer.

OPTIONS (Check/specify appropriate options)

PIPE SIZE

2, 3, 4 [51, 76, 102]
2, 3, 4 [51, 76, 102]

(Specify size/type) OUTLET

____ IP Threaded
____ NH No-Hub

PREFIXES

____ ZB D.C.C.I. Body Assembly w/ Polished Bronze Top
____ ZN D.C.C.I. Body Assembly w/ Polished Nickel Bronze Top*

SUFFIXES

____ -P Trap Primer Connection (Specify 1/2 [13] or 3/4 [19])
____ -PC Protective Cover
____ -U 1 - 3 [25 - 76] High Extension Adapter
____ -VP Vandal-Proof Secured Top
____ -Y Sediment Bucket

* Regularly furnished unless otherwise specified.