



Z610-122

12 [305] SQUARE TOP DRAIN W/ DEEP SUMP BODY AND
VANDAL PROOF, POLISHED NICKEL BRONZE VENEERED
SOLID COVER W/ 2-1/2 [64] CENTERED HOLE

SPECIFICATION SHEET

TAG _____

Dimensional Data (inches and [mm]) are Subject to Manufacturing Tolerances and Change Without Notice

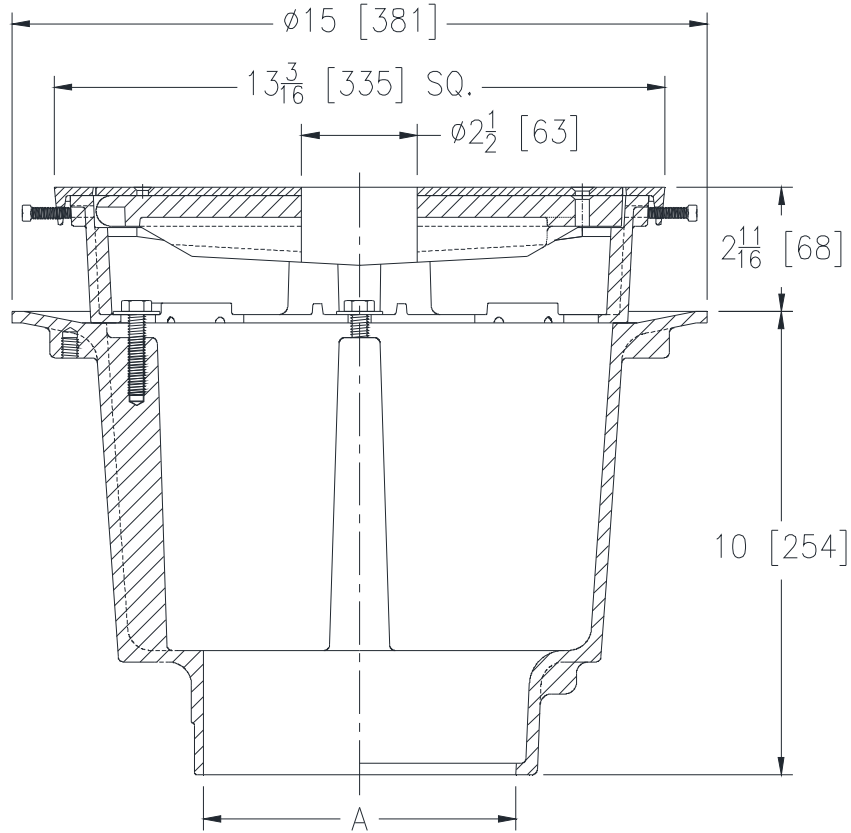

A Pipe Size In.	Approx. Wt. Lbs. [kg]
3, 4 [76, 102]	75 [34]
6, 8 [152, 203]	

ENGINEERING SPECIFICATION: ZURN Z610-122

12 [305] Square top drain, Dura-Coated cast iron deep sump body with bottom outlet, seepage pan and combination membrane flashing clamp, and frame with vandal proof, polished nickel bronze veneered solid cover with 2-1/2 [69] diameter centered hole.

OPTIONS (Check/specify appropriate options)

PIPE SIZE

- 3, 4, 6 [76, 102, 152]
- 3, 4, 6, 8 [76, 102, 152, 203]
- 3, 4 [76, 102]

(Specify size/type) **OUTLET**

- _____ IC Inside Caulk
- _____ NH No-Hub
- _____ NL Neo-Loc

'E' BODY HT. DIM.

- 10 [254]
- 10 [254]
- 9-5/16 [237]

PREFIXES

- _____ **ZN** D.C.C.I. Body with Polished Nickel Bronze Top*

SUFFIXES

- _____ **-DG** Duresist Grate
- _____ **-DX** Dex-o-tex flange
- _____ **-G** Galvanized Cast Iron
- _____ **-H** Hinged Grate
- _____ **-HL** Hinged Locking Grate
- _____ **-Y** Sediment Bucket

REV.	DATE: 04/04/13	C.N. NO. 129088
PROD./DWG NO. Z610-122		

*REGULARLY FURNISHED UNLESS OTHERWISE SPECIFIED