



Z1172-169

**SIZE 1100 LARGE CAPACITY GREASE INTERCEPTOR
W/ ANCHOR FLANGE, EXTENSION, & HEAVY-DUTY COVER**

SPECIFICATION SHEET

TAG _____

Dimensional Data (inches and [mm]) are Subject to Manufacturing Tolerances and Change Without Notice

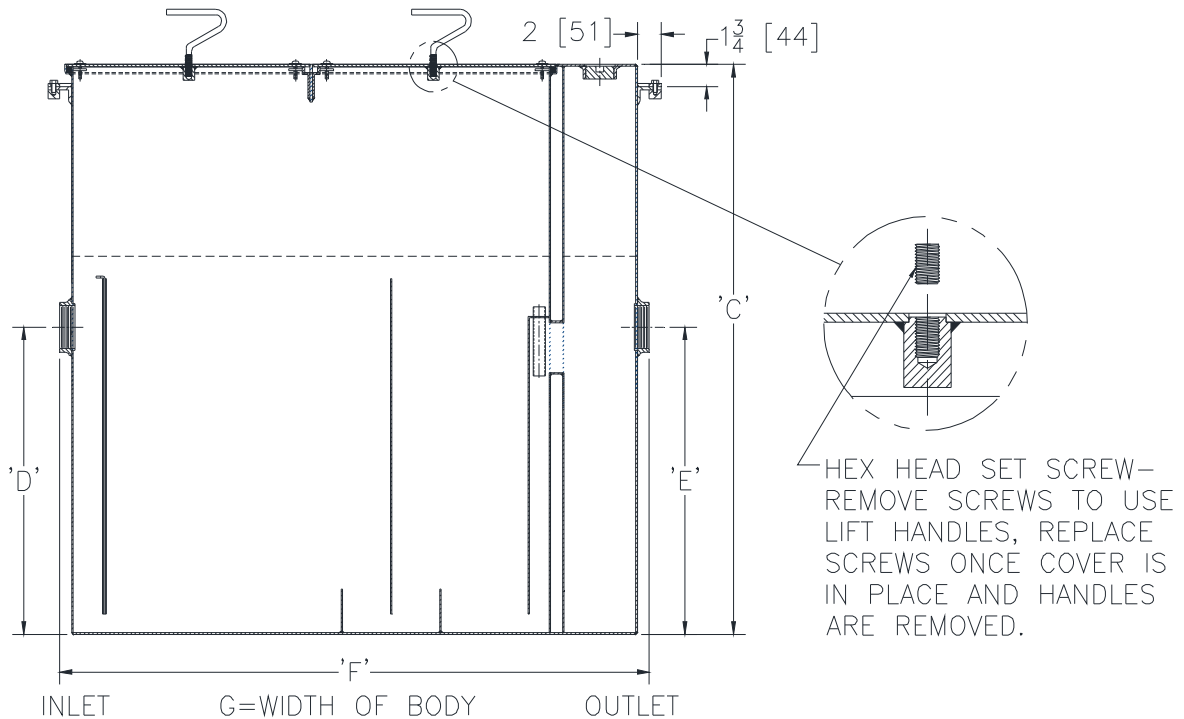

Size	Inlet/Outlet Size	Flow Rate G.P.M. [L]	Capacity		No. of Covers	Approx. Wt. Lbs. [kg]	Dimension in Inches			
			Water Gal. [L]	Grease Lbs. [kg]			C	D/E	F	G
1100	4 [102]	125 [472]	150 [567]	250 [114]	2	1225 [556]	57-1/8 [1451]	24-1/2 [622]	49-1/4 [1251]	40 [1016]

ENGINEERING SPECIFICATION: ZURN Z1172-169

Large capacity Acid Resistant Coated interior and exterior fabricated steel grease interceptor with anchor flange and clamp collar, rated at 125 GPM and 250 Lbs. grease capacity, with internal air relief by-pass, bronze cleanout plug (which can be used as a sampling port) and visible double wall trap seal with removable pressure equalizing/flow diffusing baffle. Gasketed non-skid heavy-duty secured traffic cover rated at 10,000 lbs [4536] safe live load with removable lift handles, complete with flow control fitting. Acid resistant epoxy coated interior and exterior fabricated steel extension built integral to the interceptor body. Regularly furnished with inlet and outlet in high position.

OPTIONS (Check/specify appropriate options)

PREFIXES

- ___ Z Acid Resistant Coated Fabricated Steel*
- ___ ZS All Type 304 Fabricated Stainless Steel

SUFFIXES

- ___ -L Angle type (Z1108-L) flow control device.
- ___ -PW Plug Wrench

* Regularly furnished unless otherwise specified.