



Z1217-B

COUPLING TYPE SYSTEM - BLOWOUT WALL URINAL / SERVICE SINK

SPECIFICATION SHEET

TAG _____

Dimensional Data (inches and [mm]) are Subject to Manufacturing Tolerances and Change Without Notice

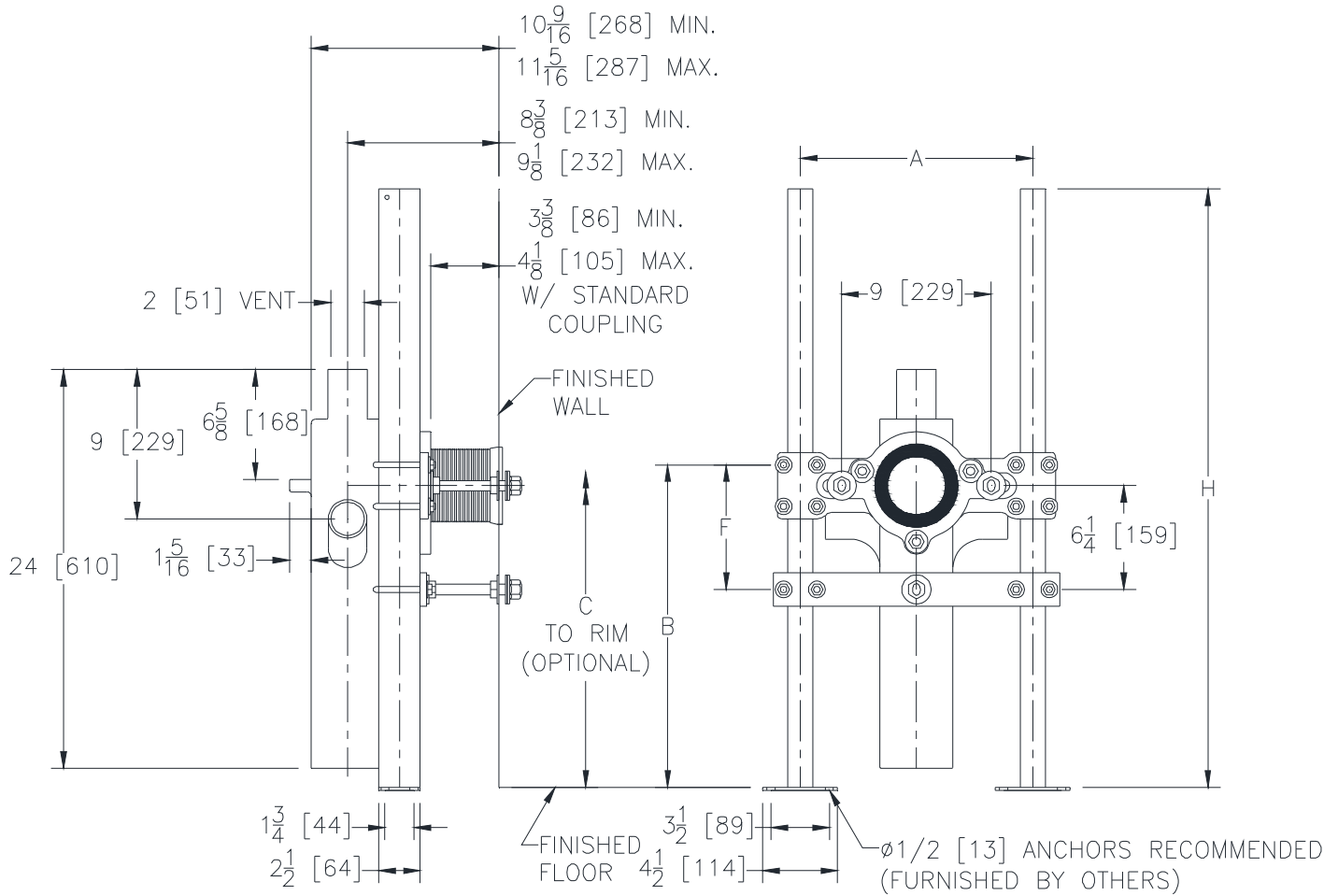

Product No.	Outlet Inches [mm]	Approx. Wt. Lbs. [kg]
Z1217-B	4 [102]	63 [29]

ENGINEERING SPECIFICATION: ZURN Z1217-B

Service sink blowout type fixture support system complete with Dura-Coated rectangular steel uprights with welded feet, adjustable face plate and lower support plate, Z1208 fitting with 2" [51mm] vent, corrosion resistant adjustable ABS coupling with integral test cap, fixture bolts, trim and bonded "Neo-Seal" gasket.

OPTIONS (Check/specify appropriate options)

PREFIXES

___ Z D.C.C.I. System with "ZZ" Coupling*

SUFFIXES

- ___ -CC Corrosion Resistant 6 [152] Long Cast Iron Coupling
- ___ -CL Coupling Length Other Than Standard 6 [152] (Specify Length Required)
- ___ -F4 Z1208 Fitting With 4 [102] Vent
- ___ -F32 3 [76] Z1208 Fitting with 2 [51] Vent
- ___ -VP Vandal Proof Trim
- ___ -WS Wall Support Valve Plate (Specify Valve Name and Number)

* Regularly furnished unless otherwise specified.

Zurn Industries, LLC | Specification Drainage Operation
 1801 Pittsburgh Avenue, Erie, PA U.S.A. 16502 · Ph. 855-663-9876, Fax 814-454-7929
 In Canada | Zurn Industries Limited
 3544 Nashua Drive, Mississauga, Ontario L4V 1L2 · Ph. 905-405-8272, Fax 905-405-1292
www.zurn.com

Rev. B
 Date: 10/17/17
 C.N. No. 138920
 Prod. | Dwg. No. Z1217-B