



# Z541-119

## 12 [305] DIAMETER TOP DRAIN WITH PERFORATED STANDPIPE & Z415 LOWER BODY

SPECIFICATION SHEET

TAG \_\_\_\_\_

Dimensional Data (inches and [ mm ]) are Subject to Manufacturing Tolerances and Change Without Notice

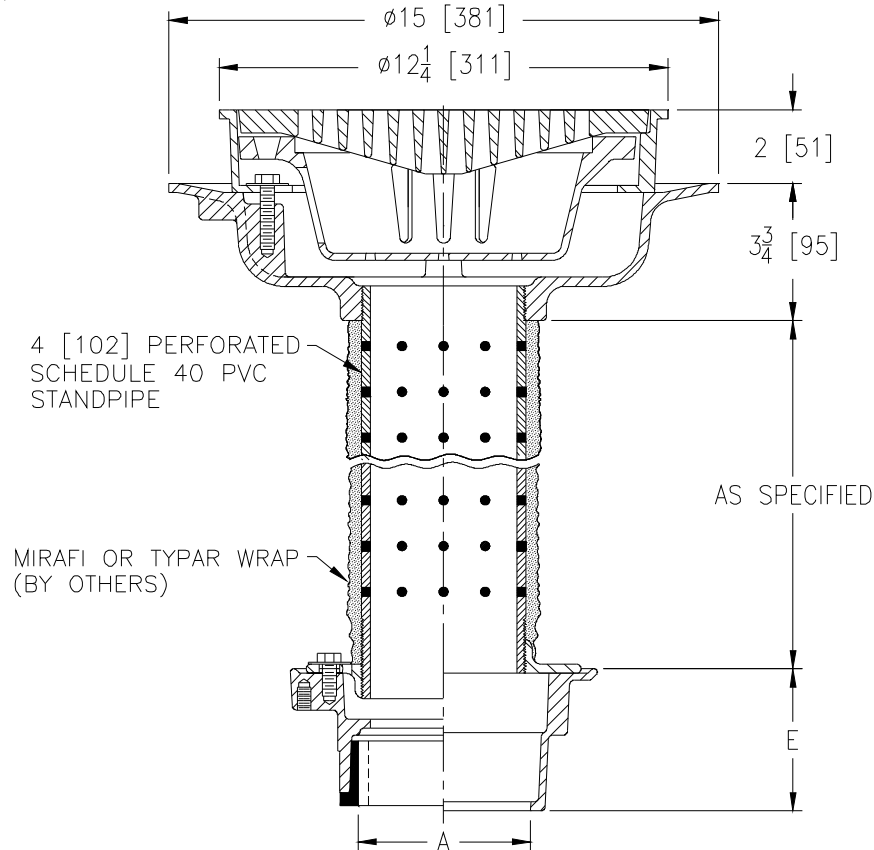

A- Pipe Size In.	Approx. Wt. Lbs. [kg]	Grate Open Area Sq. In. [cm <sup>2</sup> ]
2-3-4 [51-76-102]	66 [30]	30 [194]
6 [152]	68 [31]	

### ENGINEERING SPECIFICATION: ZURN Z541-119

12 [305] diameter top drain, Dura-Coated cast iron upper body with bottom outlet, seepage pan, and combination membrane flashing clamp and frame for anti tilt heavy-duty slotted grate, suspended sediment bucket and perforated standpipe. Lower Z415 body is Dura-Coated cast iron with combination invertible membrane clamp.

### OPTIONS (Check/specify appropriate options)

#### PIPE SIZE

2 thru 4 [51 thru 102]  
 2 [51]  
 3 [76]  
 4 [102]  
 6 [152]  
 2 thru 4 [51 thru 102]  
 2 thru 4 [51 thru 102]

#### (Specify size/type) OUTLET

\_\_\_ IC Inside Caulk  
 \_\_\_ IP Threaded  
 \_\_\_ IP Threaded  
 \_\_\_ IP Threaded  
 \_\_\_ IP Threaded  
 \_\_\_ NH No-Hub  
 \_\_\_ NL Neo-Loc

#### 'E' BODY HT. DIM.

3 7/8 [98]  
 2 3/4 [60]  
 2 5/8 [67]  
 2 7/8 [73]  
 2 3/4 [70]  
 3 7/8 [98]  
 3 3/4 [95]

### SUFFIXES

\_\_\_ -AR Acid Resisting Epoxy Coated Cast Iron  
 \_\_\_ -G Galvanized Cast Iron

REV. B DATE: 6/24/04 C.N. NO. 92317

DWG. NO. P-14386 PRODUCT NO. Z541-119

\*REGULARLY FURNISHED UNLESS OTHERWISE SPECIFIED

ZURN INDUSTRIES, INC. ♦ SPECIFICATION DRAINAGE OPERATION ♦ 1801 Pittsburgh Ave. ♦ Erie, PA 16514

Phone: 814/455-0921 ♦ Fax: 814/454-7929 ♦ World Wide Web: www.zurn.com

In Canada: ZURN INDUSTRIES LIMITED ♦ 3544 Nashua Drive ♦ Mississauga, Ontario L4V1L2 ♦ Phone: 905/405-8272 Fax: 905/405-1292