



Z100-EA

ADJUSTABLE ROOF DRAIN ASSEMBLY INSTALLATION INSTRUCTIONS

Dimensional data (inches and [mm]) are subject to manufacturing tolerances and change without notice.

1. Open the Z100-EA assembly and make sure the following components are included:

- A. 3/8-16 x 2-3/4 Studs – (4)
- B. 3/8 Bonded washers – (4)
- C. 3/8 Steel washers – (4)
- D. 3/8-16 Nuts – (4)
- E. 3/8-16 x 1-1/4 Bolts – (4)
- F. White Petroleum – (2)
- G. O-ring – (1)
- H. Gasket – (1)
- I. Collar – (1)
- J. Adjustable sleeve – (1)
- K. Bag of 4 extra bonded washers "B" – (1)

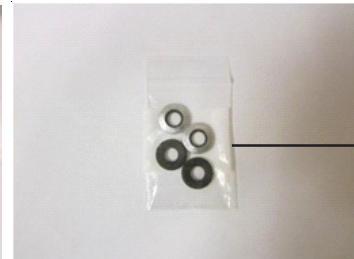
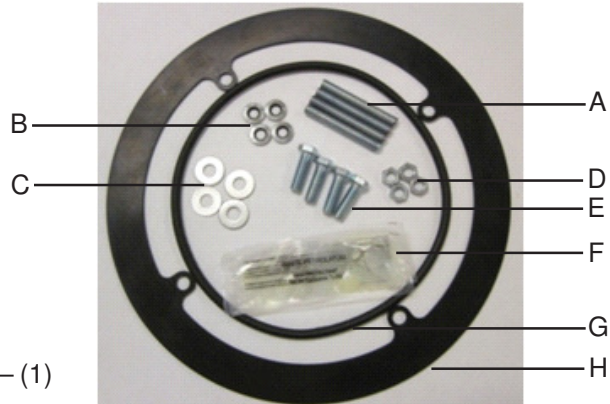

2. Fasten four (4) studs "A" into the drain body.

Note: Use a flat head screwdriver to engage the slot in each stud and make sure studs are screwed in completely.



3. Place the flat gasket "H" onto the drain body by aligning the four holes in the gasket with the studs. Make sure that the studs protrude through all four holes in the gasket and that the gasket lays flat on the drain body.



Caution: Do not confuse the bonded washers "B" that have an elastomeric backing with the flat steel washers "C".

4. Position collar "I" onto studs and down on top of the gasket. Place four (4) bonded washers "B" onto studs. The rubber on the washer must be down against the collar and the metal side of the washer must be up against the nut. Screw on four (4) nuts "D" and tighten to a minimum of 150 in-lbs.

Note: If drain is disassembled for any reason, do not re-use bonded washers. Instead, use the four (4) extra washers supplied in bag "K".

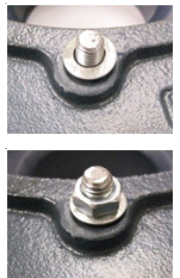

⚠ WARNING: Cancer and Reproductive Harm - www.P65Warnings.ca.gov

⚠ ADVERTENCIA: Cáncer y daño reproductivo - www.P65Warnings.ca.gov

⚠ AVERTISSEMENT: Cancer et effets néfastes sur la reproduction - www.P65Warnings.ca.gov



Z100-EA

ADJUSTABLE ROOF DRAIN ASSEMBLY INSTALLATION INSTRUCTIONS

Dimensional data (inches and [mm]) are subject to manufacturing tolerances and change without notice.

5. Apply white petroleum "F" onto the o-ring "G".
6. Insert o-ring into the groove located inside the inner diameter of the collar.



7. Apply white petroleum onto the external threads of the adjustable sleeve "J".
Note: Use any remaining petroleum completely.



8. Screw adjustable sleeve into the collar.
9. Adjust the height of the adjustable sleeve "J" to desired height.
Note: Do not exceed the maximum limit (3 1/2 inches).

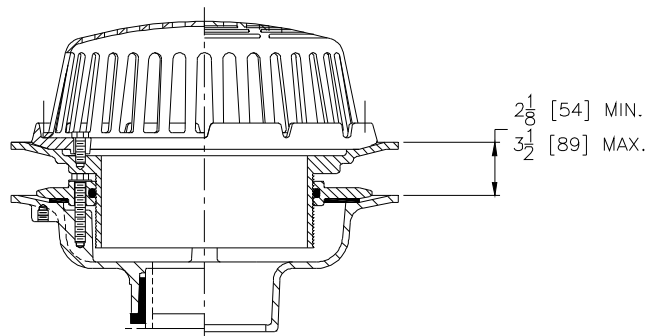

10. Align gravel guard (part of the standard drain) slots with the drilled and tapped holes in the adjustable sleeve and secure on membrane with four (4) steel washers "C" and bolts "E".

11. Attach the dome to gravel guard to complete assembly.

