



Z100-344

15 [381] DIAMETER MAIN ROOF DRAIN WITH 3" INTERNAL WATER DAM AND STAINLESS STEEL PERFORATED EXTENSION

SPECIFICATION SHEET

TAG _____

Dimensional Data (inches and [mm]) are Subject to Manufacturing Tolerances and Change Without Notice

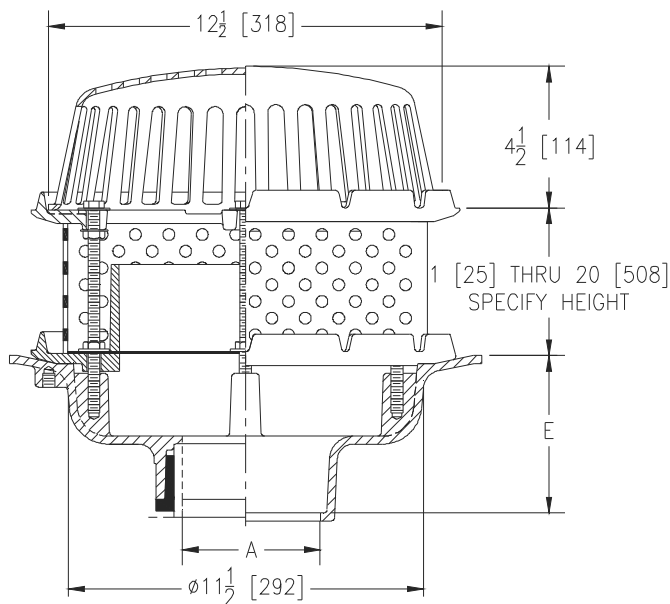

A Pipe Size In. [mm]	Approx. Wt. Lbs. [kg]	Dome Open Area Sq. In. [cm ²]
2, 3, 4 [51, 76, 102]	26 [12]	103 [665]
5, 6 [127, 152]	27 [12]	
8 [203]	28 [13]	

ENGINEERING SPECIFICATION: ZURN Z100-344

15" [381mm] Diameter roof drain. Duracoated cast iron body with combination membrane flashing clamp/gravel guard with 3" [76mm] internal water dam, Stainless Steel perforated extension, gasket and low silhouette Poly-Dome.

OPTIONS (Check/specify appropriate options)

PIPE SIZE

- 2, 3, 4, 5, 6, 8 [51, 76, 102, 127, 152, 203]
- 2, 3, 4, 5, 6, 8 [51, 76, 102, 127, 152, 203]
- 2, 3, 4, 5, 6, 8 [51, 76, 102, 127, 152, 203]
- 2, 3, 4 [51, 76, 102]
- 6 [152]

(Specify size/type) OUTLET

- _____ IC Inside Caulk
- _____ IP Threaded
- _____ NH No-Hub
- _____ NL Neo-Loc
- _____ NL Neo-Loc

E BODY HT. DIM.

- 5-1/4 [133]
- 3-3/4 [95]
- 5-1/4 [133]
- 4-9/16 [116]
- 5-7/16 [112]

PREFIXES

- _____ Z D.C.C.I. Body with Poly-Dome*
- _____ ZA D.C.C.I. Body with 6-3/4 [171] High Aluminum Dome
- _____ ZC D.C.C.I. Body with Cast Iron Dome
- _____ ZRB D.C.C.I. Body with Plain Bronze Dome

SUFFIXES

- | | |
|--|--|
| _____ -AC Angular Underdeck Clamp | _____ -G Galvanized Cast Iron |
| _____ -AR Acid Resistant Epoxy Coated | _____ -GD Galvanized Cast Iron Dome (ZC Only) |
| _____ -BS Bronze Mesh Screen Over Dome | _____ -HD 6-3/4 [171] High Aluminum Dome Strainer (148 Sq. In. [955 cm ²] Open Area) |
| _____ -C Underdeck Clamp | _____ -R Roof Sump Receiver |
| _____ -DE Deck Extension | _____ -SS Stainless Steel Mesh Screen Over Dome |
| _____ -DP Top-Set® Deck Plate (Replaces both the -C and -R) | _____ -TC Neo-Loc Test Cap Gasket (2,3,4 [51,76,102] NL Bottom Outlet Only) |
| _____ -DR Top-Set® Drain Riser | _____ -VP Vandal-Proof Secured Top |
| _____ -DX Dex-o-tex Flange | _____ -84 Stainless Steel Perforated Gravel Guard |
| _____ -E Static Extension 1 [25] thru 4 [102] (Specify Ht.) | _____ -90 90° Threaded Side Outlet Body (2, 3, 4, 5, 6 [51, 76, 102, 127, 152]) |
| _____ -EA Adjustable Extension Assembly 2-1/8 [54] thru 3-1/2 [89] | |
| _____ -EB Top-Set® Adjustable Extension Assembly | |

* Regularly furnished unless otherwise specified.