



Z1370-82

GROUND HYDRANT W/ HINGED COVER & RECESSED HANDLE (Encased, Hose Storage, Non-Freeze)

SPECIFICATION SHEET

TAG _____

Dimensional Data (inches and [mm]) are Subject to Manufacturing Tolerances and Change Without Notice

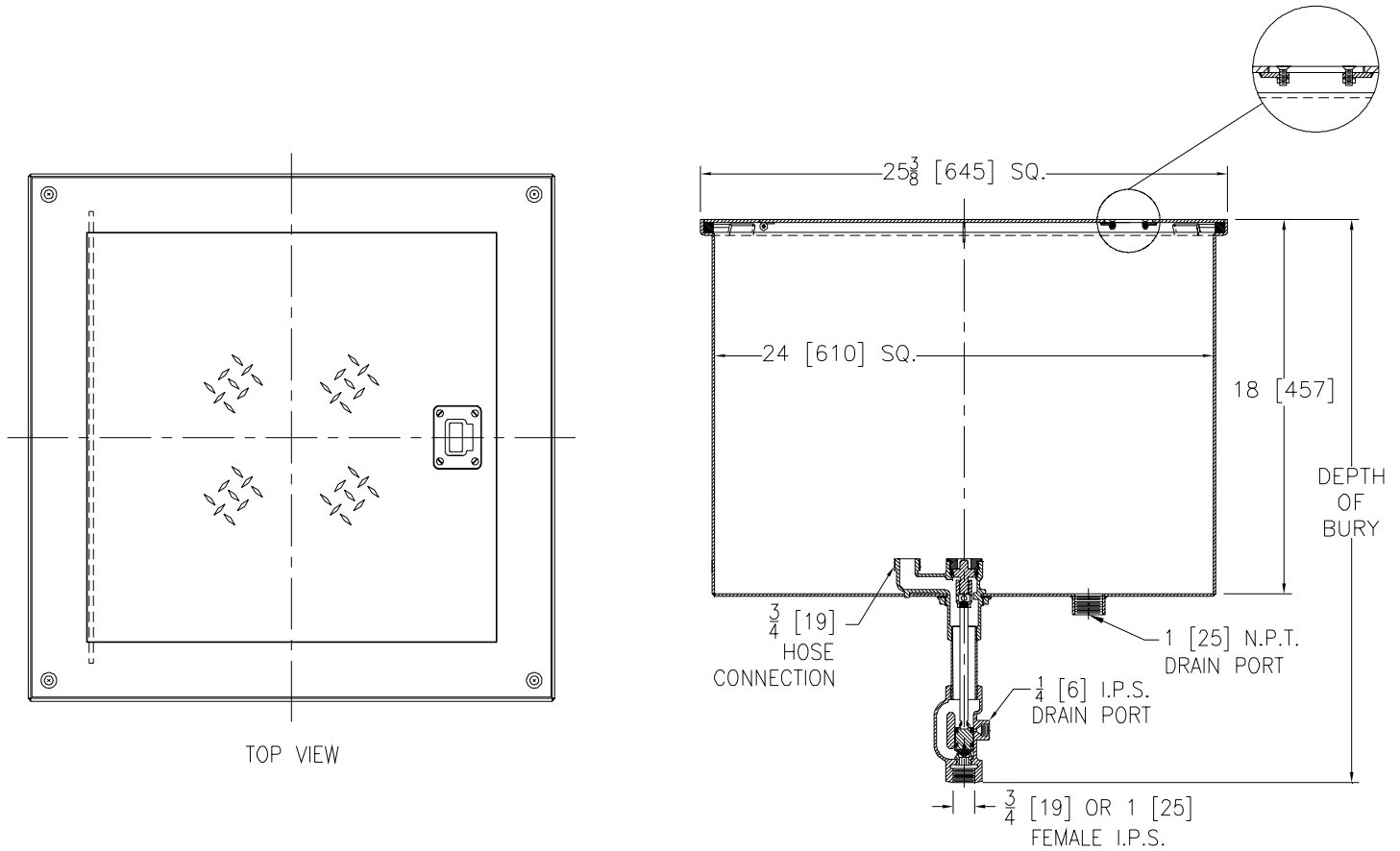

TOP VIEW

Depth of Bury	Approx. Wt. Lbs. [kg]
33 7/8 [860]	81 [37]
45 7/8 [1165]	85 [39]
57 7/8 [1470]	89 [40]
69 7/8 [1775]	93 [42]
81 7/8 [2080]	97 [44]
93 7/8 [2384]	101 [46]
105 7/8 [2689]	105 [48]
117 7/8 [2994]	109 [49]
129 7/8 [3299]	113 [51]

ENGINEERING SPECIFICATION: ZURN Z1370-82

Encased, non-freeze ground hydrant, for flush with grade or finished floor installation. Complete with galvanized steel casing, all bronze interior parts, bronze seat and replaceable seat washer, and non-turning operating rod with free-floating compression closure valve. Acid resistant coated fabricated steel box provides hose storage and is complete with gasketed scoriated stainless steel hinged cover with recessed flush lift handle. Hydrant is equipped with a tapped 1 [25] drain port in closure box and 1/4 [6] drain port in value housing. (Hose should always be disconnected for storage.)

Note:

- IMPORTANT** Hydrant must be opened one turn to seal drain port during use.

PARTS LIST

Item	Name	Quan.
5	Operating Screw	1
6	O-Ring	1
7	Operating Coupling	1
8	Operating Rod	1
9	Washer Guide	1
10	Washer (neoprene)	1
11	Screw	1
17	O-Ring	2
18	Removable Seat	1

OPTIONS (Check/specify appropriate options)

SUFFIXES

- ____ -BC Bronze Casing
- ____ -RK Hydrant Parts Repair Kit

REV. A	DATE: 05/05/08	C.N. NO. 98454
DWG. NO. P-15332	PRODUCT NO. Z1370-82	

*WHEN ORDERING REPLACEMENT PARTS SPECIFY Y DIM.