

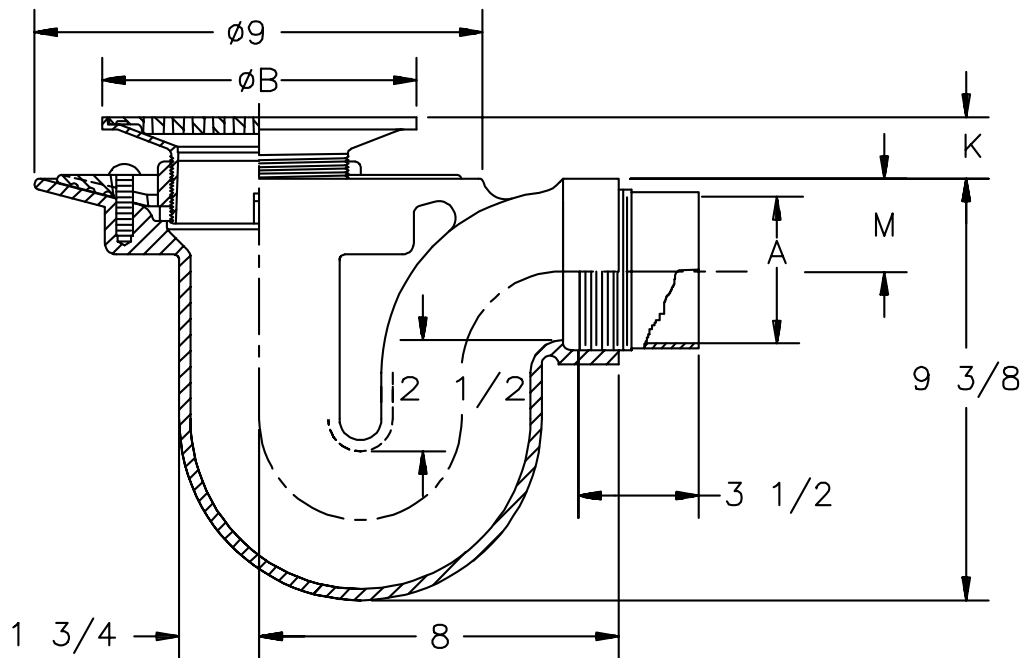

Z-453-75 DEEP SEAL TRAP DRAIN WITH Z-1040 NO-HUB ADAPTER

TAG _____

Dimensional Data (inches and [mm]) are Subject to Manufacturing Tolerances and Change Without Notice



Dimensions In Inches					Approx. Wt. Lbs.	Strainer Open Area Sq. In.
A Pipe Size	B Strainer Dia.	K		M		
		Min.	Max.			
2-3	5	3/4	1 7/8	2 1/8	30	8
4						
2-3	6	1 1/8	2 1/8	2 1/8	31	9
4						
2-3	7	1 3/8	2 1/2	2 1/8	33	12
4						
4	8	1 3/8	2 1/2	2 3/4	33	18
4	10	1 7/8	2 7/8	2 3/4	35	26

ENGINEERING SPECIFICATION: ZURN Z-453-75 Deep Seal trap floor and shower drain with Z-1040 No-Hub adapter, Dura-Coated cast iron body with uniform diameter integral trap, side outlet, seepage pan, and adjustable "TYPE B" polished, nickel bronze strainer.

OPTIONS (Check/specify appropriate options)

OUTLET (Specify type)
 _____ IP Threaded

PIPE SIZE (Specify size)
 _____ 2", 3", 4"

'E' BODY HT. DIMENSION
 9 3/8

PREFIXES

_____ **ZB-** D.C.C.I. Body Assembly with Polished Bronze Top
 _____ **ZN-** D.C.C.I. Body Assembly with Polished Nickel Bronze Top*

SUFFIXES

_____ **-C** Clamping Collar
 _____ **-G** Galvanized Cast Iron
 _____ **-J** Auxiliary Inlet (Specify 1 1/2 or 2)
 _____ **-P** Trap Primer Connection (Specify 1/2 or 3/4)
 _____ **-U** 3 High Extension Adaptor
 _____ **-VP** Vandal Proof Secured Top

REV.	DATE: 5/10/95	C.N. NO. 71838
DWG NO. P-14174	PRODUCT NO. Z-453-75	

*REGULARLY FURNISHED UNLESS OTHERWISE SPECIFIED