



# Z1210-29

## MECHANICAL TEST CAP ASSEMBLY FOR WATER CLOSET CARRIERS

SPECIFICATION SHEET

TAG \_\_\_\_\_

Dimensional Data (inches and [ mm ]) are Subject to Manufacturing Tolerances and Change Without Notice

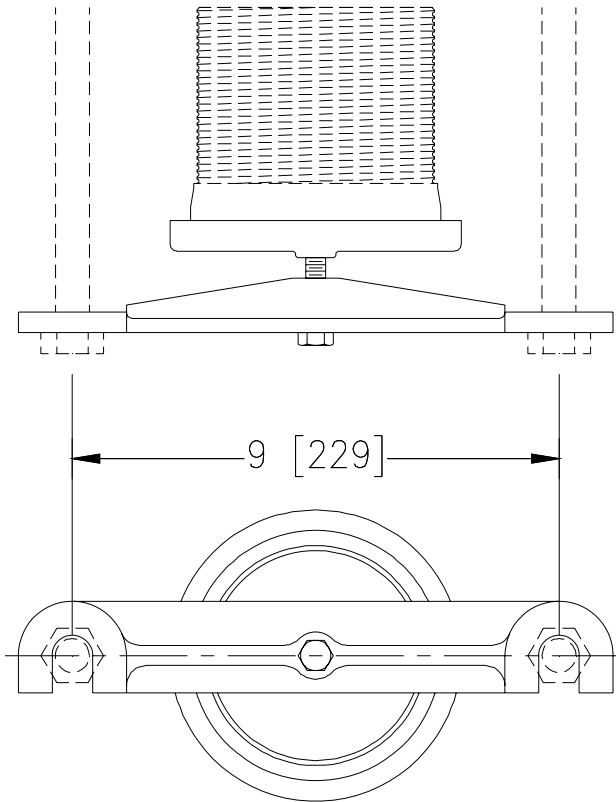

**ENGINEERING SPECIFICATION:** ZURN Z1210-29 Cast Iron test cap and straddle bar with gasket and adjustment bolt for water closet carriers.

\*REGULARLY FURNISHED UNLESS OTHERWISE SPECIFIED

REV.            DATE: 7/9/09            C.N. NO. 120173

DWG.NO.84261            PRODUCT NO. Z1210-29

ZURN INDUSTRIES, LLC ♦ SPECIFICATION DRAINAGE OPERATION ♦ 1801 Pittsburgh Ave. ♦ Erie, PA 16514

Phone: 814/455-0921 ♦ Fax: 814/454-7929 ♦ World Wide Web: www.zurn.com

In Canada: ZURN INDUSTRIES LIMITED ♦ 3544 Nashua Drive ♦ Mississauga, Ontario L4V1L2 ♦ Phone: 905/405-8272 Fax: 905/405-1292