

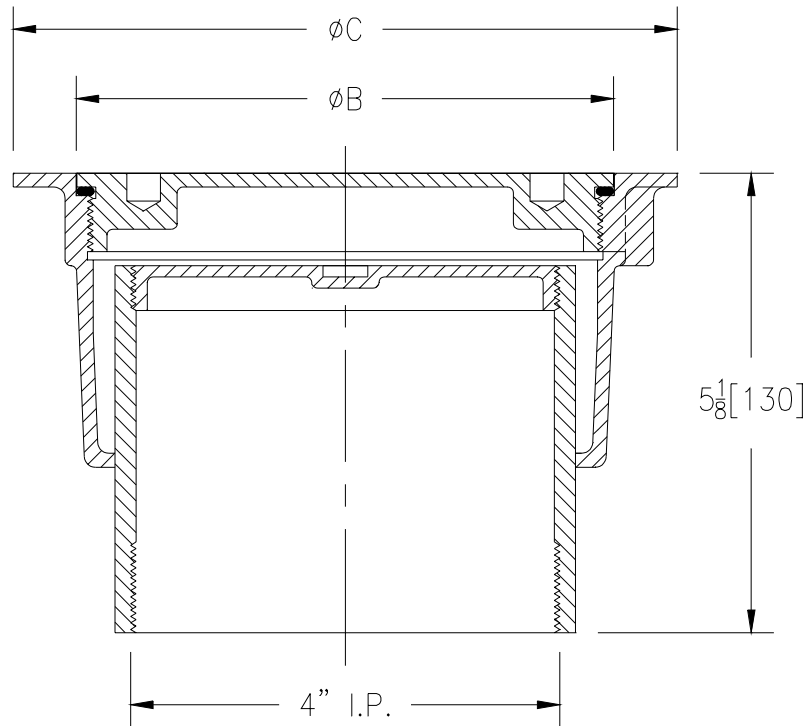

Z-1745-77
FLOOR CLEANOUT WITH O-RING SEAL PLUG
AND CLOSURE PLUG

TAG _____

Dimensional Data (inches and [mm]) are Subject to Manufacturing Tolerances and Change Without Notice



Dimensions in Inches			Approx. Wt. Lbs.
A- Pipe Size	B	C	
4 [100]	4 1/2 [114]	6 [152]	6 [3]

ENGINEERING SPECIFICATION: ZURN Z-1745-77
 All Type 304 (CF8) stainless steel cleanout body, plug with O-ring seal (plug is scoriated with satin finish) and stainless steel closure plug. Spanner wrench provided for each plug size.

OPTIONS (Check/specify appropriate options)

PIPE SIZE (Specify size/type) **OUTLET**
 4 [100] _____ IP Threaded

PREFIXES
 _____ Z- Type 304 (CF8) Stainless Steel Body*
 _____ ZC- Type A-27 Carbon Steel Body (P.O.A.)
 _____ ZM- Type 316 (CF8M) Stainless Steel Body

SUFFIXES
 _____ -SW Spanner Wrench

REV.	DATE: 11/22/96	C.N. NO. 76570
DWG. NO. P-14421 PRODUCT NO. Z-1745-77		

*REGULARLY FURNISHED UNLESS OTHERWISE SPECIFIED