



Z895-99

13-1/2 [343] REVEAL ELEVATOR TRENCH DRAIN SYSTEM WITH 2-1/4 [57] SUMP DEPTH

SPECIFICATION SHEET

TAG _____

Dimensional Data (inches and [mm]) are Subject to Manufacturing Tolerances and Change Without Notice

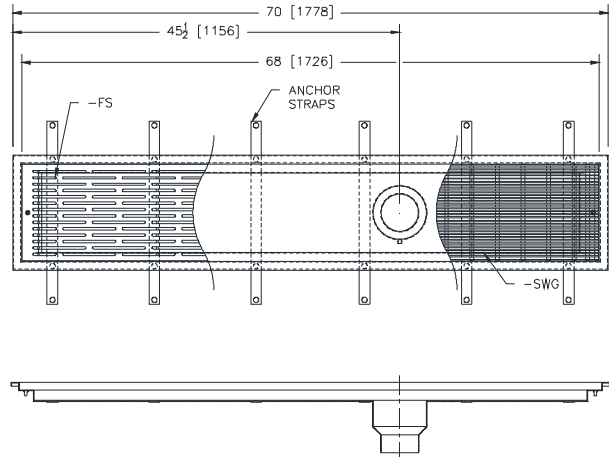
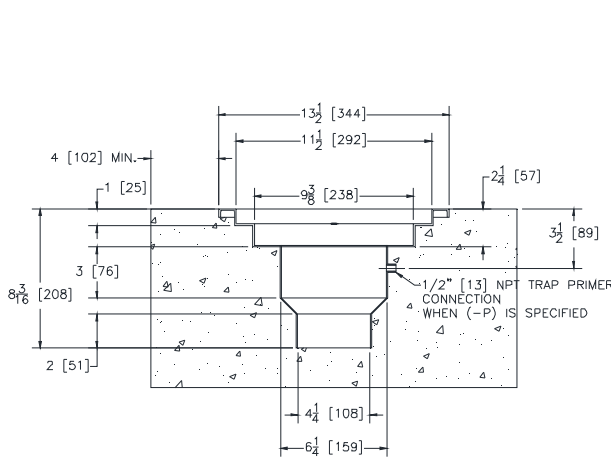

ENGINEERING SPECIFICATION: The Zurn Z895-99

Overall channel width shall be 13-1/2" [343mm] and have an 9-3/8" [238mm] throat. Channels are made of #12 ga. fabricated stainless steel conforming to ASTM A-240 (type 304) and will include anchoring straps. Channel to be provided with custom -SWG stainless steel wire grate, conforming to ASTM A-240 (type 304), that locks down to the channel with vandal-proof flathead machine screws. This grate is rated for Class A per the DIN EN1433 top load classification, complies with both ADA and Heel-Proof requirements, and has an open area of 64.9 sq. in/ft. [1373.7 sq. cm/m]. Optional -FS fabricated slotted grate has an open area of 35.91 sq. in/ft [760.1 sq. cm/m] and also complies with ADA and Heel-Proof requirements. This system has been designed to comply with SFFC Code, Section 511.1 for a 100 GPM flow rate.

Note: Minimum Dimensional requirements must be met to satisfy 100 GPM flow rate specification.

Prefix Options (Check/specify appropriate options)

Z Type 304 Stainless Steel*

Grate Options

- FS Fabricated Stainless Steel Slotted Grate (open area = 35.9 sq-in / linear foot)
- SWG Stainless Wire Grate* (open area = 64.9 sq-in / linear foot)*

Suffix Options (Check/specify appropriate options)

- 4NH 6 [152] to 4 [102] Custom Tapered No-Hub Bottom Outlet*
- 6NH 6 [152] No-Hub Bottom Outlet

Miscellaneous Options

- DX DX Flange
- P 1/2 [13] Trap Primer Connection
- LAS Less Anchor Straps

* Regularly furnished unless otherwise specified.

** Flow rate calculated based on head depth to top of channel.