



Z-1753-75

12" X 12" X 6" [305 X 305 X 153]
DEEP SANI-FLOR RECEPTOR

TAG _____

WITH PERIMETER DRAINAGE AND BELL TRAP BUCKET

Dimensional Data (inches and [mm]) are Subject to Manufacturing Tolerances and Change Without Notice

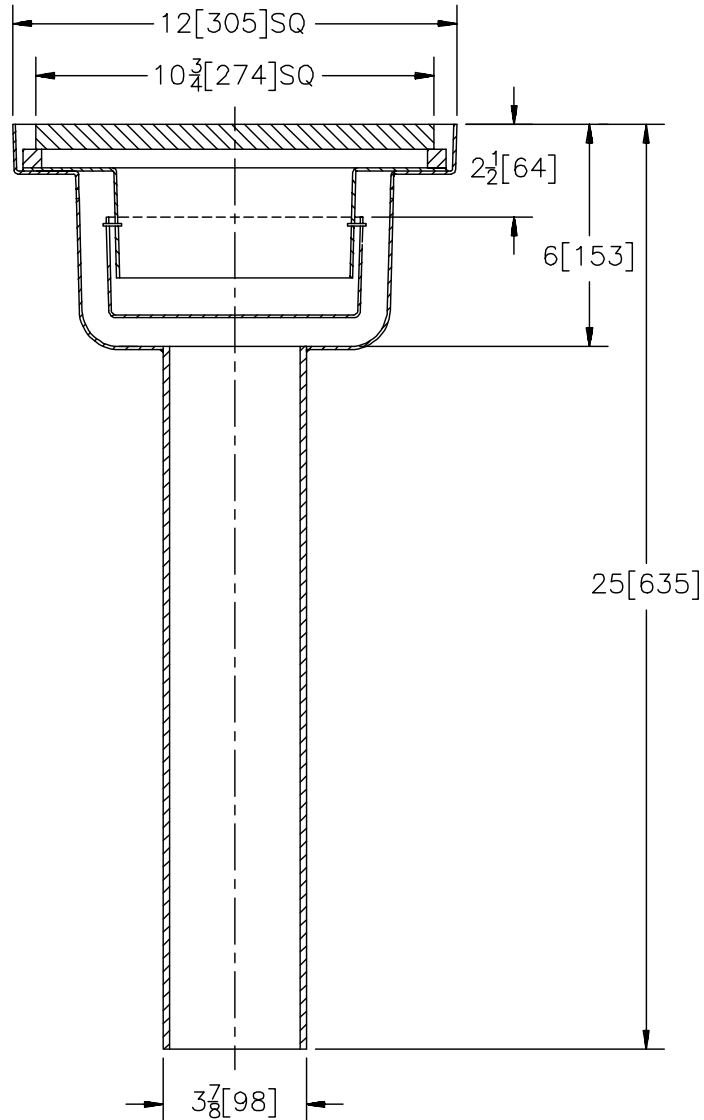

| |
|-----------------------------|
| Approx. Wt. Lbs. [kg] |
| 15 [7] |

ENGINEERING SPECIFICATIONS: ZURN Z-1753-75 12 x 12 x 6 [305 x 305 x 153] deep, All Type 304 (CF8) Stainless Steel Sani-Flor receptor with non-tilt, 1/2 [13] thick solid cover with perimeter drainage, bell trap and sediment bucket. Wheel load rating 15,000 Lbs. Drain body must be supported by concrete pour.

OPTIONS (Check/specify appropriate options)

PREFIXES

___ Z- Type 304 (CF8) Stainless Steel*

SUFFIXES

- ___ -K SeepagePan
- ___ -KC Seepage Pan With Clamp Collar
- ___ -P 1/2 [13] Trap Primer Connection
- ___ -SR 1/2 [13] Thick Sanitary Rim at Top of Drain Body

| | | |
|--|---------------|----------------|
| REV. | DATE: 6/25/99 | C.N. NO. 82894 |
| DWG. NO. P-14262 PRODUCT NO. Z-1753-75 | | |

*REGULARLY FURNISHED UNLESS OTHERWISE SPECIFIED