



Z874-18-HDG

18 [457] WIDE THROAT TRENCH DRAIN SYSTEM W/HEAVY-DUTY GALVANIZED FRAME

SPECIFICATION SHEET

TAG _____

Dimensional Data (inches and [mm]) are Subject to Manufacturing Tolerances and Change Without Notice

SPECIFYING ENGINEER IS
RESPONSIBLE FOR CONCRETE
ENCASEMENT AND
REINFORCING BASED UPON
APPLICATION AND LOCAL CODES

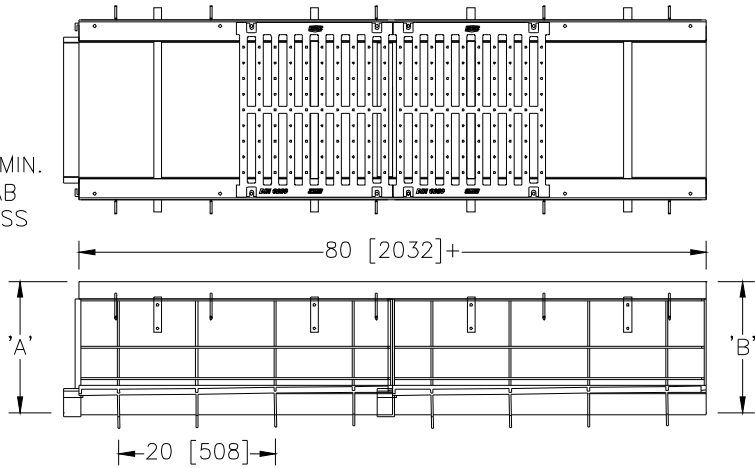
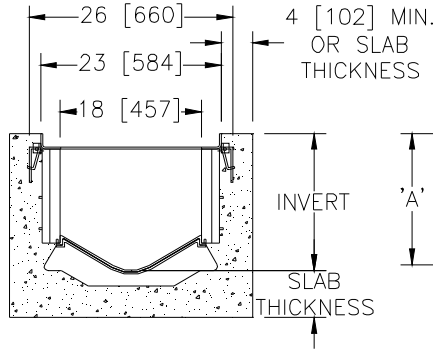

+Actual High Density Polyethylene channel length is 82 [2083] to allow for overlap, with frame attached the length is 84-1/2 [2146] with the exception of P.N. 2101P and 2130P.

ENGINEERING SPECIFICATION: Zurn Z874-18-HDG Channels shall be 80 [2032] long, 23 [584] wide reveal and have an 18 [457] wide throat. Modular channel sections shall be made of 0% water absorbent High Density Polyethylene (HDPE). Shall have a positive mechanical connection between channel sections that will not separate during the installation and shall mechanically lock into the concrete surround every 10 [254]. Channels shall weigh less than 9 lbs. [4.1kg] per linear foot, have smooth 5 [127] radiused self cleaning bottom with a Manning's coefficient of 0.009 and 1.00% or neutral 0% built-in slope. Channels are available with inverts ranging from 10.25 [260] to 35.21 [894]. Channel shall have all grates locked down. Channels come with clips attached to the frame to accommodate vertical rebar for positioning and anchoring purposes. Shall be provided with the standard GDC grate, Zurn 23 [584] wide reveal Galvanized Ductile Iron Slotted Grate, which locks down to the frame with 4 contiguous bolt anchors per grate. Ductile Iron conforms to ASTM specification A536-84, Grade 80-55-06 and Galvanizing conforms to ASTM specification A123. Galvanized Ductile Iron grate is rated class C per the DIN EN1433 top load classifications. Supplied in 20[508] nominal lengths with 1-1/32 [26] wide slots, and 1-3/4 [44] bearing depth. Grate has an open area of 112 sq. in. pr ft. [237078 sq. mm per meter]. The 1/4 [6] thick Galvanized Carbon Steel Frame Assembly conforms to ASTM specification A36 and Galvanizing conforms to ASTM specification A123 with 10 - 4 [102] long concrete anchors per 80 [2032]. All welds must be performed by a certified welder per ASTM standard AWS D1.1. Frames shall be produced in the USA.

PREFIX

___ Z 80 [2032] High Density Polyethylene Channel, Heavy-Duty Galvanized Frame with Anchor Studs*

SUFFIX OPTIONS (Check/specify appropriate options)

Adapters

- ___ -E1 Closed End Cap
- ___ -E4 4 [102] No-Hub End Outlet
- ___ -E6 6 [152] No-Hub End Outlet
- ___ -E8 8 [203] No-Hub End Outlet
- ___ -E12 12 [305] No-Hub End Outlet
- ___ -U4 4 [102] No-Hub Bottom Outlet
- ___ -U6 6 [152] No-Hub Bottom Outlet
- ___ -U8 8 [203] No-Hub Bottom Outlet
- ___ -U18 18 [457] No-Hub Bottom Outlet

Grate Options (Load Classifications are per DIN EN1433)

- ___ -DCC Ductile Iron Solid Cover - Class C
- ___ -DCF Ductile Iron Solid Cover - Class F
- ___ -DGC Ductile Iron Slotted Grate - Class C*
- ___ -DGF Ductile Iron Slotted Grate - Class F
- ___ -GDC Galvanized Ductile Iron Grate - Class C
- ___ -GDF Galvanized Ductile Iron Grate - Class F
- ___ -GG Fiberglass Grate
- ___ -HPD Heel-Proof Longitudonal Ductile Iron Grate - Class C

MADE in the U.S.A. (Load Classifications are per DIN EN1433)

- ___ -DGE-USA Ductile Iron Slotted Grate - Class E
- ___ -GDE-USA Galvanized Ductile Slotted Grate - Class E

MADE in the U.S.A. Miscellaneous Options

- ___ -DB Bottom Dome Strainer

*REGULARLY FURNISHED UNLESS OTHERWISE SPECIFIED

Trench No.	'A' Shallow Inv.	'B' Deep Inv.	Flow		
			(gpm)	(lps)	(cfs)
1801P	10.250 [260]	11.082 [281]	3058	193	6.85
1802P	11.082 [281]	11.914 [303]	3589	226	8.04
1803P	11.914 [303]	12.746 [324]	4132	261	9.26
1804P	12.746 [324]	13.578 [345]	4685	296	10.50
1805P	13.578 [345]	14.410 [366]	5247	331	11.76
1806P	14.410 [366]	15.242 [387]	5816	367	13.04
1807P	15.242 [387]	16.074 [408]	6392	403	14.33
1808P	16.074 [408]	16.906 [429]	6973	440	15.63
1809P	16.906 [429]	17.738 [451]	7559	477	16.94
1810P	17.738 [451]	18.570 [472]	8149	514	18.27
1811P	18.570 [472]	19.402 [493]	8743	552	19.60
1812P	19.402 [493]	20.234 [514]	9340	589	20.93
1813P	20.234 [514]	21.066 [535]	9940	627	22.28
1814P	21.066 [535]	21.898 [556]	10542	665	23.63
1815P	21.898 [556]	22.730 [577]	11147	703	24.98
1816P	22.730 [577]	23.562 [598]	11753	741	26.34
1817P	23.562 [598]	24.394 [620]	12362	780	27.71
1818P	24.394 [620]	25.226 [641]	12972	818	29.08
1819P	25.226 [641]	26.058 [662]	13584	857	30.45
1820P	26.058 [662]	26.890 [683]	14198	896	31.82
1821P	26.890 [683]	27.722 [704]	14812	934	33.20
1822P	27.722 [704]	28.554 [725]	15428	973	34.58
1823P	28.554 [725]	29.386 [746]	16045	1012	35.96
1824P	29.386 [746]	30.218 [768]	16663	1051	37.35
1825P	30.218 [768]	31.050 [789]	17282	1090	38.74
1826P	31.050 [789]	31.882 [810]	17901	1129	40.12
1827P	31.882 [810]	32.714 [831]	18522	1168	41.52
1828P	32.714 [831]	33.546 [852]	19143	1208	42.91
1829P	33.546 [852]	34.378 [873]	19765	1247	44.30
1830P	34.378 [873]	35.210 [894]	20388	1286	45.70

(Neutral channels available for all section numbers)

REV. - DATE: 3/10/11 C.N. NO. 120431

DWG. NO. 303411 PRODUCT NO. Z874-18-HDG

ZURN INDUSTRIES, LLC ♦ SPECIFICATION DRAINAGE OPERATION ♦ 1801 Pittsburgh Ave. ♦ Erie, PA 16514

Phone: 814/455-0921 ♦ Fax: 814/454-7929 ♦ World Wide Web: www.zurn.com

In Canada: ZURN INDUSTRIES LIMITED ♦ 3544 Nashua Drive ♦ Mississauga, Ontario L4V1L2 ♦ Phone: 905/405-8272 Fax: 905/405-1292