



Z1172-122

ADJUSTABLE RECESSING RECEIVER FOR GREASEPTOR WITH FLOW CONTROL FITTING AND CLEANOUT ACCESS PLATE

SPECIFICATION SHEET

TAG _____

Dimensional Data (inches and [mm]) are Subject to Manufacturing Tolerances and Change Without Notice

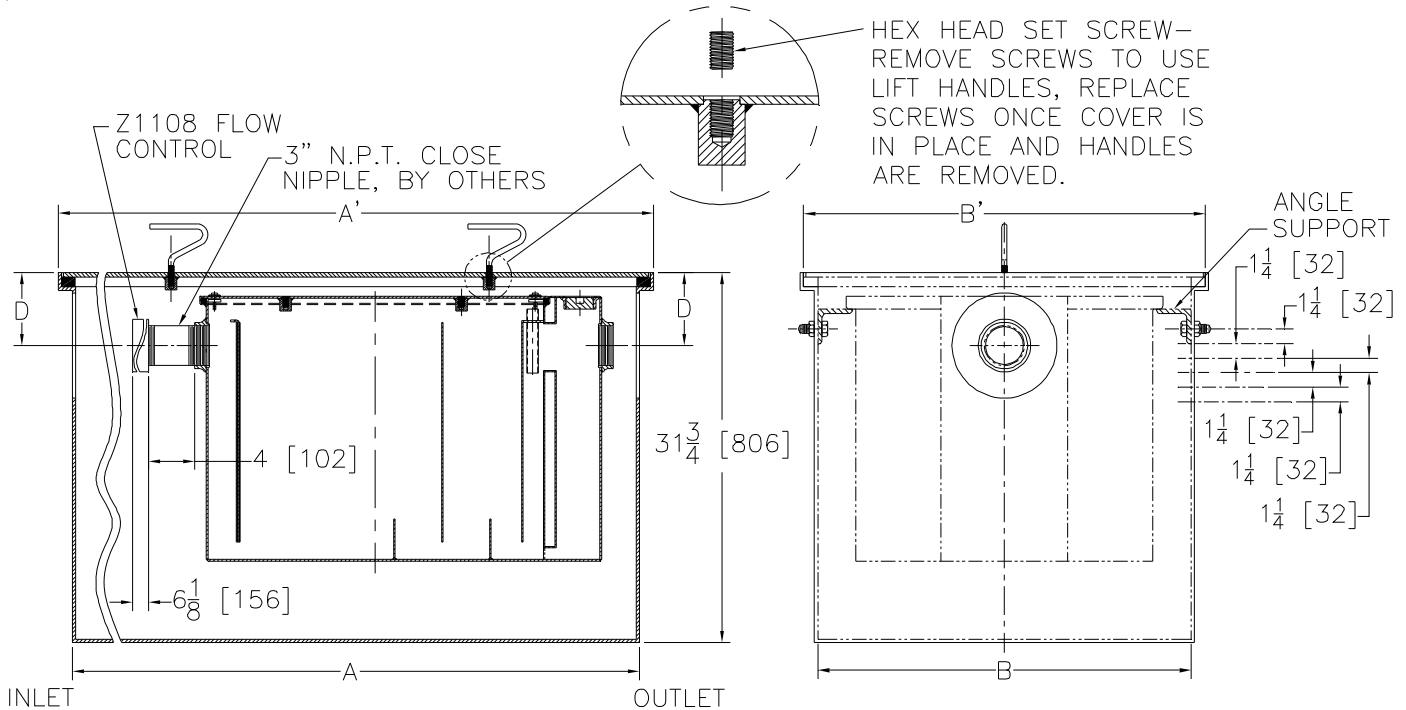

Size	Dimensions in Inches				
	A	A'	B	B'	D
900	53 1/4 [1353]	55 1/4 [1403]	32 1/8 [816]	34 1/8 [867]	6 1/4 [159]

ENGINEERING SPECIFICATION: ZURN Z1172-122

Large capacity Acid Resistant Coated interior and exterior fabricated steel grease interceptor, rated at 75 GPM and 150 Lbs. grease capacity, with internal air relief by-pass, bronze cleanout plug and visible double wall trap seal with removable pressure equalizing/flow diffusing baffle. Gasketed non-skid secured cover with covered removable lift handles, complete with flow control fitting. For greaseptor specifications see Z1172 drawing.

PREFIXES

___ Z Acid Resistant Coated Fabricated Steel*

SUFFIXES

- ___ -K Anchor flange 1 3/4 [44] down from top and 2 [51] wide. A 3 [76] minimum extension height is required when anchor flange (-K) option is specified.
- ___ -KC Anchor flange 1 3/4 [44] down from top and 2 [51] wide with clamp collar. A 3 [76] minimum extension height is required when anchor flange (-KC) option is specified.

*REGULARLY FURNISHED UNLESS OTHERWISE SPECIFIED

REV. A	DATE: 11/26/07	C.N. NO. 97753
DWG. NO. P-15106	PRODUCT NO. Z1172-122	

ZURN INDUSTRIES, LLC. ♦ SPECIFICATION DRAINAGE OPERATION ♦ 1801 Pittsburgh Ave. ♦ Erie, PA 16514

Phone: 814455-0921 ♦ Fax: 814454-7929 ♦ World Wide Web: www.zurn.com

In Canada: ZURN INDUSTRIES LIMITED ♦ 3544 Nashua Drive ♦ Mississauga, Ontario L4V1L2 ♦ Phone: 905405-8272 Fax: 905405-1292