



Z546-78

SPECIFICATION SHEET

21 1/2 [546] DIAMETER EXTRA-HEAVY-DUTY DRAIN W/EXTENSION FRAME, TRAP PRIMER CONNECTION, AND HALF-GRATE

TAG _____

Dimensional Data (inches and [mm]) are Subject to Manufacturing Tolerances and Change Without Notice

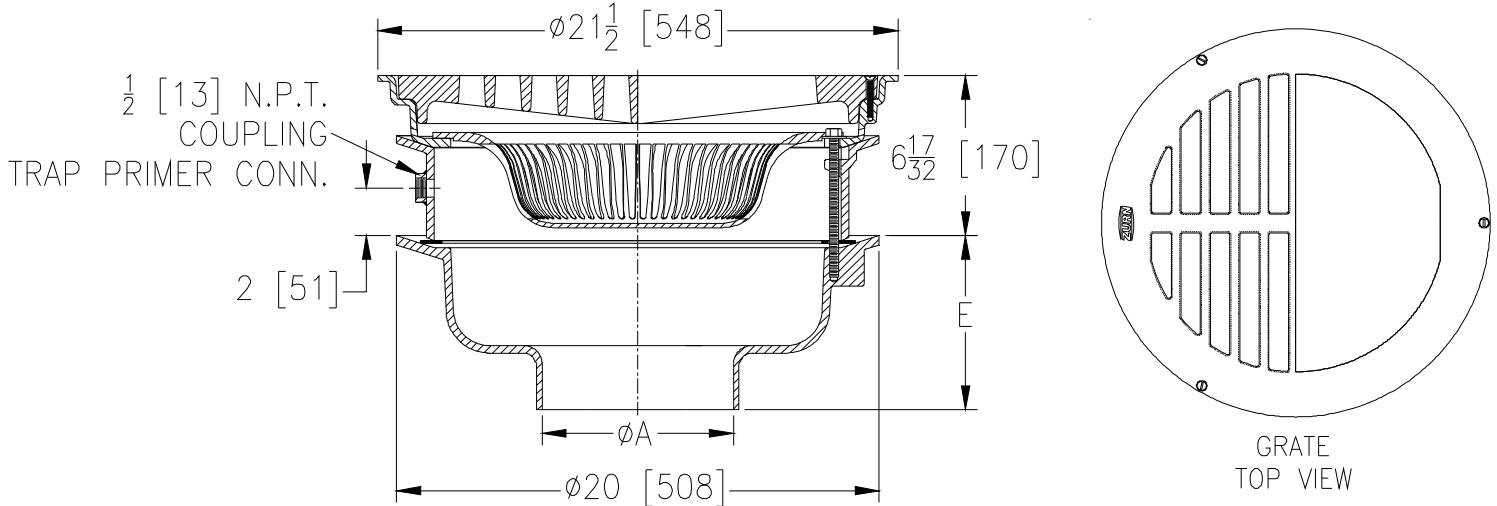

A - Pipe Size	Approx. Wt. Lbs. [kg]	Grate Open Area Sq. In. [cm ²]
8-10-12 [203-254-305]	173 [78]	146 [940]

ENGINEERING SPECIFICATION: ZURN Z546-78

21 1/2 [546] Diameter top drain, Dura-Coated cast iron body with bottom outlet, seepage pan and combination membrane flashing clamp and frame with seepage holes, extra-heavy-duty cast iron slotted half grate with suspended sediment bucket, gasketed extension frame, and trap primer connection.

OPTIONS (Check/specify appropriate options)

PIPE SIZE

8-10-12 [203 - 254 - 305]

(Specify size/type) OUTLET

___ NH No-Hub

'E' BODY HT. DIM.

7 5/16 [186]

PREFIXES

___ Z D.C.C.I. Body and Top*

SUFFIXES

- ___ -DG Duresist Grate
- ___ -G Galvanized Cast Iron
- ___ -LY Less Sediment Bucket
- ___ -TS Top Secured with Slotted Screws
- ___ -VP Vandal-Proof Secured Top

*REGULARLY FURNISHED UNLESS OTHERWISE SPECIFIED

REV. DATE: 12/16/09 C.N. NO. 110529

DWG. NO. P-15811 PRODUCT NO. Z546-78

ZURN INDUSTRIES, LLC. ♦ SPECIFICATION DRAINAGE OPERATION ♦ 1801 Pittsburgh Ave. ♦ Erie, PA 16514

Phone: 814/455-0921 ♦ Fax: 814/454-7929 ♦ World Wide Web: www.zurn.com

In Canada: ZURN INDUSTRIES LIMITED ♦ 3544 Nashua Drive ♦ Mississauga, Ontario L4V1L2 ♦ Phone: 905/405-8272 Fax: 905/405-1292