



ZN1910-K

8-9/16 x 8-9/16 [217 x 217] A.R.E. SANI-FLOR RECEPTOR
6 [152] SUMP DEPTH WITH ANCHOR FLANGE AND
NICKEL BRONZE FRAME AND GRATE

SPECIFICATION SHEET

TAG _____

Dimensional Data (inches and [mm]) are Subject to Manufacturing Tolerances and Change Without Notice

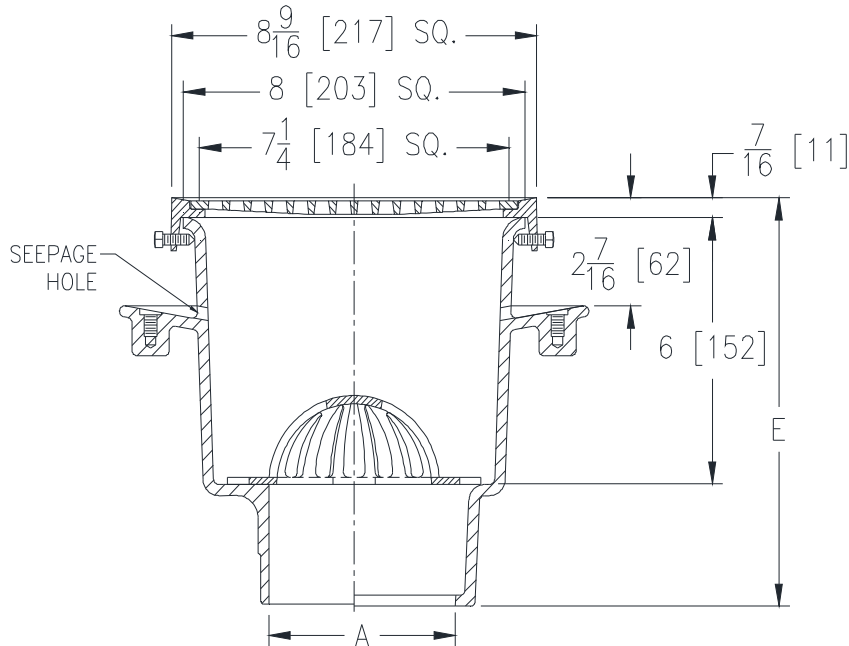

A Pipe Size In. [mm]	Approx Wt. Lbs. [kg]	Grate Open Area Sq. In. [cm ²]
2,3,4 [51,76,102]	25 [11]	19 [123]

ENGINEERING SPECIFICATION: ZURN ZN1910-K

Sani-Flor Receptor 8-9/16" x 8-9/16" x 6" [217mm x 217mm x 152mm] deep cast iron body with anchor flange, seepage holes, white acid resisting porcelain enamel interior, black ground enamel exterior coating, square nickel bronze frame and full grate, complete with white ABS anti-splash interior bottom dome strainer.

OPTIONS (Check/specify appropriate options)

PIPE SIZE

3,4 [76,102]
2,3,4 [51,76,102]
2,3,4 [51,76,102]

(Specify size/type) OUTLET

___ IC Inside Caulk
___ NH No-Hub
___ NL Neo-Loc

'E' BODY HT. DIMENSION

9-3/16 [233]
9-1/16 [230]
8-7/16 [214]

PREFIXES

___ ZN Cast Iron Body with White A.R.E. Interior, 8-9/16 [217] Square Nickel Bronze Frame and Full Grate with 5/16 [8] Square Openings *

SUFFIXES

___ -DX	Dex-O-Tex Flange	___ -11	Vandal-Proof Secured Grate
___ -LD	Less Bottom Dome Strainer	___ -15	Solid Loose Set Cover
___ -P	1/2 [13] Trap Primer Connection (See Z1023)	___ -19	Full Hinged Grate
___ -TC	Neo-Loc Test Cap Gasket (2,3,4 [51,76,102] NL Bottom Outlet Only)	___ -23	Aluminum Bucket
___ -1	Less Grate	___ -25	White A.R.C. Bucket
___ -2	1/2 Grate	___ -31	Stainless Steel Mesh Liner for Bucket
___ -3	3/4 Grate	___ -32	Aluminum Dome Strainer
___ -4	Full Grate with Square Center Opening	___ -33	White A.R.C. Anti-Splash Bottom Dome Strainer
___ -6	Grate w/ 6 [152] Diameter x 6 [152] High Funnel		
___ -8	Grate w/ 8-7/8 x 3-5/8 x 3-3/4 [225 x 92 x 95] High Oval Funnel		

* Regularly furnished unless otherwise specified.

Zurn Industries, LLC | Specification Drainage Operation
1801 Pittsburgh Avenue, Erie, PA U.S.A. 16502 · Ph. 855-663-9876, Fax 814-454-7929
In Canada | Zurn Industries Limited
3544 Nashua Drive, Mississauga, Ontario L4V 1L2 · Ph. 905-405-8272, Fax 905-405-1292
www.zurn.com

Rev. C
Date: 10/12/17
C.N. No. 138778
Prod. | Dwg. No. ZN1910-K