



Z662-93

SPECIFICATION SHEET

16 [406] SQ. TOP DRAIN EXTRA-HEAVY-DUTY W/ Z415 LOWER BODY & Z1030 ADAPTER

TAG _____

Dimensional Data (inches and [mm]) are Subject to Manufacturing Tolerances and Change Without Notice

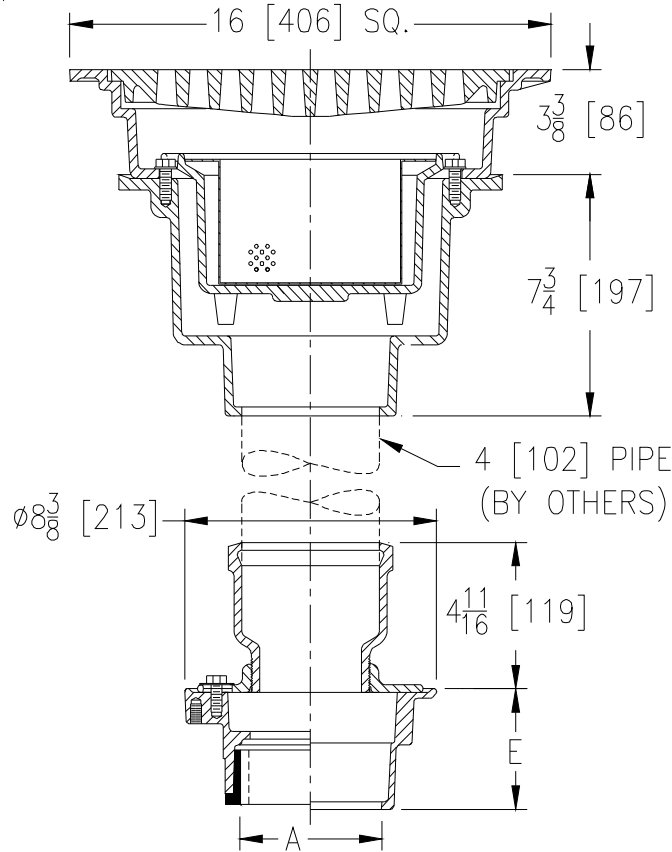

A - Pipe Size In.	Approx. Wt. Lbs. [kg]	Grate Open Area Sq. In. [cm ²]
2-3-4-6 [51-76-102-152]	95 [43]	53 [342]

ENGINEERING SPECIFICATION: ZURN Z662-93 16 [406] Square top drain, Dura-Coated cast iron lower body with bottom outlet, combination invertible membrane clamp, Z1030 No-Hub adapter, dura-coated cast iron upper body with combination membrane flashing clamp and vandal proof secured top with frame for extra-heavy-duty duresist grate with aluminum sediment bucket and stainless mesh liner.

OPTIONS (Check/specify appropriate options)

PIPE SIZE

- 2 thru 4 [51 thru 102]
- 2 [51]
- 3 [76]
- 4 [102]
- 6 [152]
- 2 thru 4 [51 thru 102]
- 2 thru 4 [51 thru 102]

(Specify size/type) **OUTLET**

- _____ IC Inside Caulk
- _____ IP Threaded
- _____ IP Threaded
- _____ IP Threaded
- _____ IP Threaded
- _____ NH No-Hub
- _____ NL Neo-Loc

'E' BODY HT. DIM.

- 3 7/8 [98]
- 2 3/8 [60]
- 2 5/8 [67]
- 2 7/8 [73]
- 2 3/4 [70]
- 3 7/8 [98]
- 3 3/4 [95]

PREFIXES

- _____ Z D.C.C.I. Body and Grate*
- _____ ZB D.C.C.I. Body Assembly w/Polished Bronze Top (Add 3/16 [5] to 3 3/8 [86] and 11/16 [17] to 16 [406] Dim.)
- _____ ZN D.C.C.I. Body Assembly w/Polished Nickel Bronze Top(Add 3/16 [5] to 3 3/8 [86] and 11/16 [17] to 16 [406] Dim.)

SUFFIXES

- _____ -AR Acid Resisting Epoxy Coated Cast Iron (Lower Body)
- _____ -G Galvanized Cast Iron
- _____ -P Trap Primer Connection (Specify 1/2 [13] or 3/4 [19]) (Lower Body)
- _____ -V Backwater Valve
- _____ -90 90° Threaded Side Outlet Body (2 [50], 3 [75] Lower Body Only)

REV. A	DATE: 6/24/04	C.N. NO. 92315
DWG. NO. P-14257 PRODUCT NO. Z662-93		

*REGULARLY FURNISHED UNLESS OTHERWISE SPECIFIED