



Z-625-77

ISOLATION DECK ADJUSTABLE DRAIN WITH ROUND STRAINER WITH DEEP FLANGED GRATE

TAG _____

Dimensional Data (inches and [mm]) are Subject to Manufacturing Tolerances and Change Without Notice

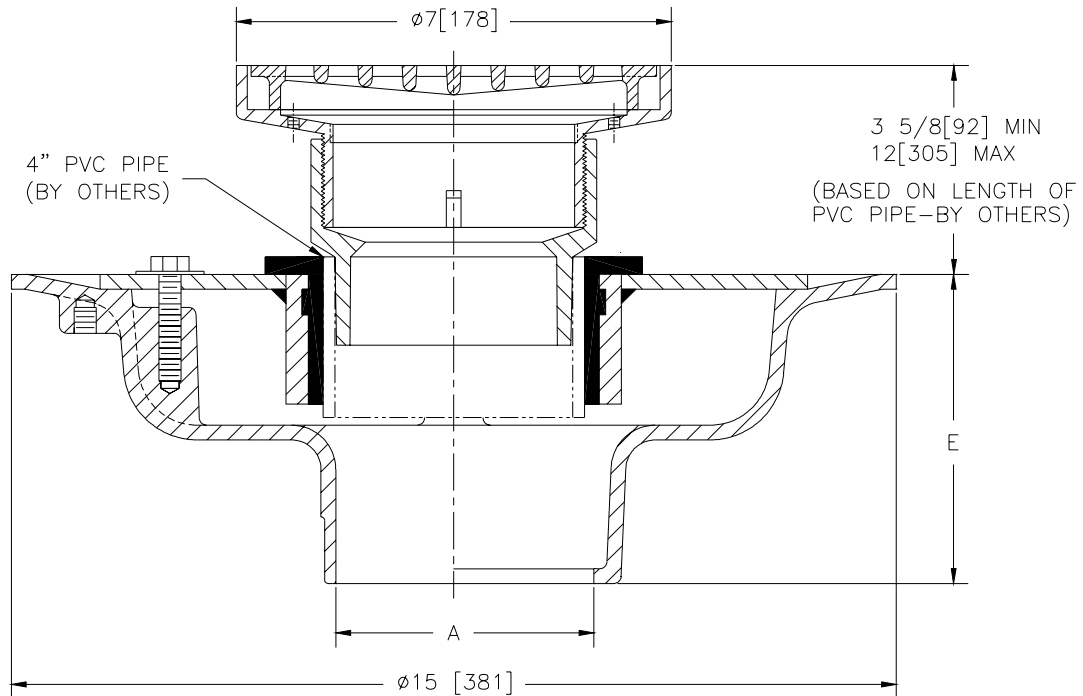

A- Pipe Size In.	Approx. Wt. Lbs. [kg]	Grate Open Area Sq. In. [cm ²]
2-3-4 [50-75-100]	38 [17]	12 [77]
5-6 [125-150]		

ENGINEERING SPECIFICATION: ZURN ZN-625-77 Adjustable isolation deck drain, Dura-Coated cast iron lower body with clamp collar and neoprene flex gasket. Upper PVC adjustable adapter for solvent welding into 4" PVC pipe with adjustable 4" NPSM 7N nickel bronze round strainer and deep flanged grate.

OPTIONS (Check/specify appropriate options)

PIPE SIZE	(Specify size/type) OUTLET	'E' BODY HT. DIM.
2 thru 6 [50 thru 150]	___ IC Inside Caulk	5 1/4 [133]
2 thru 4, 6 [50 thru 100, 150]	___ IG Inside Caulk w/Sealtrol Gskt.	5 1/4 [133]
2 thru 6 [50 thru 150]	___ IP Threaded	3 3/4 [95]
2 thru 6 [50 thru 150]	___ NH No-Hub	5 1/4 [133]
2 thru 4 [50 thru 100]	___ NL Neo-Loc	4 5/8 [117]

PREFIXES

- ___ ZB- D.C.C.I Body w/Polished Bronze Top
- ___ ZN- D.C.C.I Body w/Polished Nickel Bronze Top*

SUFFIXES

- ___ -C Underdeck Clamp
- ___ -G Galvanized Cast Iron
- ___ -R Sump Receiver
- ___ -VP Vandal Proof Secured Top
- ___ -Y Sediment Bucket

REV.	DATE: 10/8/97	C.N. NO. 78762
DWG. NO. P-14525		PRODUCT NO. Z-625-77

*REGULARLY FURNISHED UNLESS OTHERWISE SPECIFIED