



# Z100F-EA FLOFORCE™ ROOF DRAIN WITH ADJUSTABLE EXTENSION INSTALLATION INSTRUCTIONS

Design and Dimensional Data (inches and [ mm ]) are Subject to Manufacturing Tolerances and Change Without Notice

1. The flange of the extension body must be installed so that it is no higher than the roof membrane, to prevent retention of water on the roof and affect flow rate through the drain. Likewise, the flange should not be installed any lower than what is approved by the involved roofing products of the project, to prevent a detrimental effect on the flow rate of the drain.
2. Position the flat extension gasket onto the top surface of the drain body so that the bolt holes in the gasket correspond with the tappings in the body. Ensure that the gasket is not twisted, folded, or misaligned.
3. Place the extension collar onto the gasket, aligning the bolt holes in the collar with the bolt holes in the gasket.
4. Insert clamping collar hardware through the holes and hand tighten down in a star pattern progressively.
5. Tighten the bolts securely in a progressive cross-body pattern to 25 ft-lbs maximum torque. **Warning: Over-torque of the bolts can cause damage to the clamping collar and/or drain body, and compromise sealing of the membrane. DO NOT use an impact driver to tighten down the hardware.**
6. Using lubricant provided, lubricate the o-ring and place the o-ring into the internal groove of the clamping collar. Ensure that the o-ring is not crimped, twisted or misaligned.
7. Lubricate the external threads of the adjustable extension sleeve and thread the sleeve down into the clamping collar. Ensure that the sleeve is set at a sufficient height to engage and properly compress the o-ring. **Warning: Failure to set the extension sleeve within the defined allowable extension range may result in failure to seal around the o-ring (See Z100F-EA specification sheet).**
8. Insert the threaded studs provided into each bolt hole of the extension sleeve and thread down until hand-tight.
9. Install roof insulation (as required) and secure a waterproofing membrane to the roof drain body with the clamping collar.
  - a. Apply the water proofing membrane fully over the roof drain extension sleeve.
  - b. Create bolt clearance holes in the membrane at corresponding stud locations.
  - c. Using appropriate manufacturer's sealant seal the membrane to the drain body per manufacturer's instructions.
  - d. Align the clamping collar bolt holes with the threaded studs and set the collar onto the membrane and extension sleeve.
  - e. Apply provided jam nuts onto the threaded studs and hand tighten down in a star pattern progressively.
  - f. If reinforced membranes are used or the membrane is suspended above drain, and hardware is used to pull membrane down to drain body, hardware must be tightened in a progressive cross-body pattern (See Form #RD139). **Warning: Forcing membrane down to drain body using only two opposite bolts can break the clamping collar and is not covered under product warranty.**
  - g. Tighten the nuts securely in a progressive cross-body pattern to 25 ft-lbs maximum torque. **Warning: Over-torque of the nuts can cause damage to the clamping collar and/or extension sleeve, and compromise sealing of the membrane. DO NOT use an impact driver to tighten down the hardware.**
10. Cut the membrane as per the roof membrane manufacturer's requirements in the center of the clamping collar. Continue to cut outward until the precast cutting edge in the extension body is located (Fig 1 ). Once precast edge is found, cut out circular section of membrane by following the cutting edge. **Warning: Failure to properly cut the membrane along the prescribed cut edge of the extension body may result in decreased flow performance of the roof drain.**
11. Align the dome inside of the clamping collar and rotate clockwise until dome is engaged and secured.

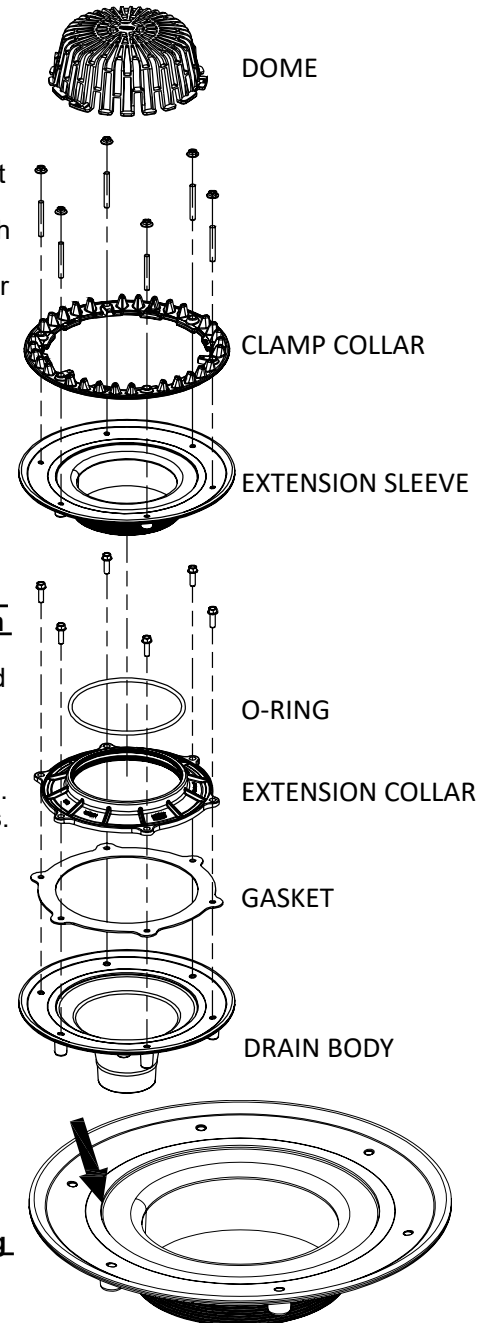

Fig. 1

Note: For additional drain installation instructions, reference Zurn document Form #RD139.

⚠ **WARNING:** Cancer and Reproductive Harm - [www.P65Warnings.ca.gov](http://www.P65Warnings.ca.gov)

⚠ **ADVERTENCIA:** Cáncer y daño reproductivo - [www.P65Warnings.ca.gov](http://www.P65Warnings.ca.gov)

⚠ **AVERTISSEMENT:** Cancer et effets néfastes sur la reproduction - [www.P65Warnings.ca.gov](http://www.P65Warnings.ca.gov)

Zurn Industries, LLC | Specification Drainage Operation  
1801 Pittsburgh Avenue, Erie, PA 16502, Ph. 855.663.9876

In Canada | Zurn Industries Limited  
7900 Goreway Drive, Unit 10, Brampton, Ontario L6T 5W6, Ph. 877.892.5216

[www.zurn.com](http://www.zurn.com)

Rev. A  
Date: 05/05/2022  
C.N. No. 144476  
Form No. RD143

Page 1 of 1