



# ZA100-239

SPECIFICATION SHEET

15 [381] DIA. ROOF DRAIN W/ UNDERDECK CLAMP, ADJ. EXTENSION, ROOF SUMP RECEIVER, ST'L. STEEL PERFORATED EXT., 4 [102] HIGH INTERNAL WATER DAM AND ALUMINUM DOME STRAINER W/ BRONZE MESH SCREEN

TAG \_\_\_\_\_

Dimensional Data (inches and [mm]) are Subject to Manufacturing Tolerances and Change Without Notice

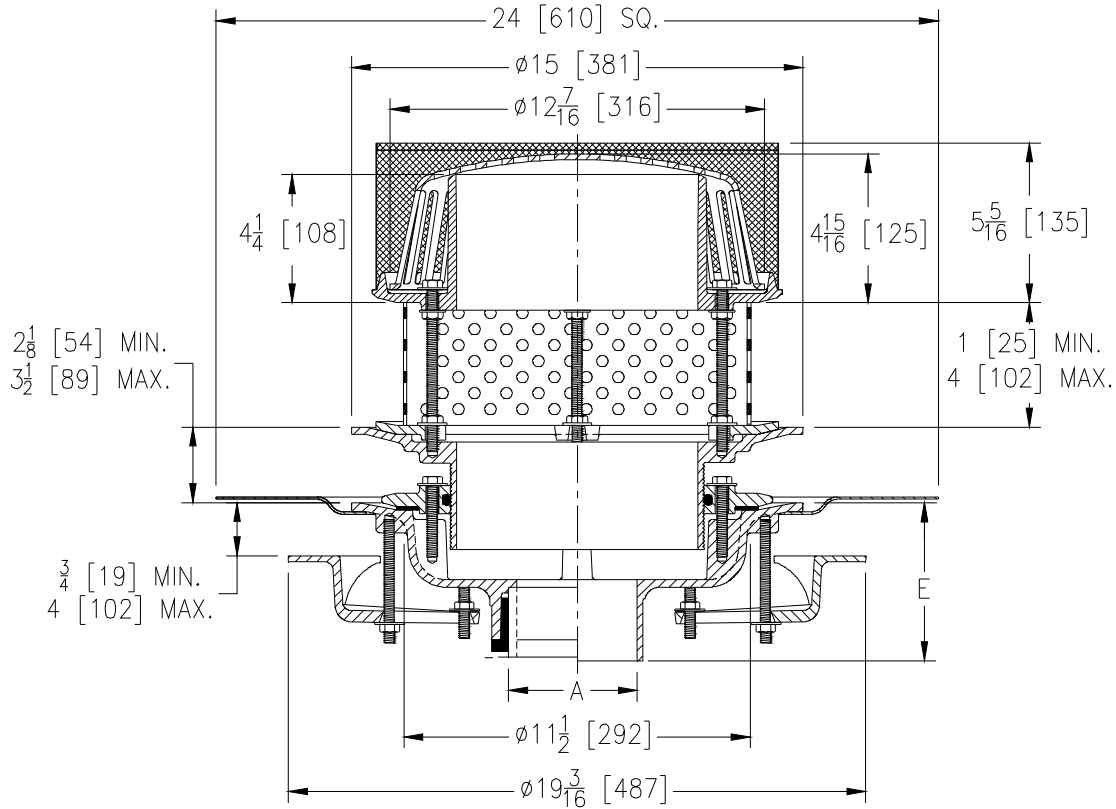

A Pipe Size In.	Approx. Wt. Lbs. [kg]	Dome Open Area Sq. In. [cm <sup>2</sup> ]
2,3,4 [51,76,102]	54 [24]	103 [665]
5,6 [127,152]	55 [25]	
8 [203]	54 [24]	

### ENGINEERING SPECIFICATION: ZURN ZA100-239

15 [381] Diameter roof drain. Dura-Coated cast iron body with combination membrane flashing clamp/gravel guard, adjustable extension, underdeck clamp, roof sump receiver, stainless steel perforated extension, 4 [102] high internal water dam and aluminum dome strainer with bronze mesh screen.

### OPTIONS (Check/specify appropriate options)

#### PIPE SIZE

- 2 thru 6,8 [51 thru 152,203]
- 2 thru 6,8 [51 thru 152,203]
- 2 thru 6,8 [51 thru 152,203]
- 2,3,4 [51,76,102]
- 6 [152]

#### (Specify size/type) OUTLET

- \_\_\_\_\_ IC Inside Caulk
- \_\_\_\_\_ IP Threaded
- \_\_\_\_\_ NH No-Hub
- \_\_\_\_\_ NL Neo-Loc
- \_\_\_\_\_ NL Neo-Loc

#### E BODY HT. DIM.

- 5 1/4 [133]
- 3 3/4 [95]
- 5 1/4 [133]
- 4 9/16 [116]
- 5 7/16 [112]

#### PREFIXES

- \_\_\_\_\_ ZA D.C.C.I. Body with Aluminum Dome\*

#### SUFFIXES

- \_\_\_\_\_ -AR Acid Resistant Epoxy Coated
- \_\_\_\_\_ -G Galvanized Cast Iron
- \_\_\_\_\_ -ST Dome with Solid Top
- \_\_\_\_\_ -TC Neo-Loc Test Cap Gasket  
(2 - 4 [51 - 102] NL Bottom Outlet Only)
- \_\_\_\_\_ -VP Vandal-Proof Secured Top

\*REGULARLY FURNISHED UNLESS OTHERWISE SPECIFIED

REV. - DATE: 8/25/11 C.N. NO. 121991

DWG. NO. 302121 PRODUCT NO. ZA100-239

ZURN INDUSTRIES, LLC ♦ SPECIFICATION DRAINAGE OPERATION ♦ 1801 Pittsburgh Ave. ♦ Erie, PA 16514

Phone: 814/455-0921 ♦ Fax: 814/454-7929 ♦ World Wide Web: www.zurn.com

In Canada: ZURN INDUSTRIES LIMITED ♦ 3544 Nashua Drive ♦ Mississauga, Ontario L4V1L2 ♦ Phone: 905/405-8272 Fax: 905/405-1292