



# Z1181-97

## SOLIDS INTERCEPTOR FOR ANIMAL HAIR APPLICATIONS W/ INTEGRAL EXTENSION

SPECIFICATION SHEET

TAG \_\_\_\_\_

Dimensional Data (inches and [ mm ]) are Subject to Manufacturing Tolerances and Change Without Notice

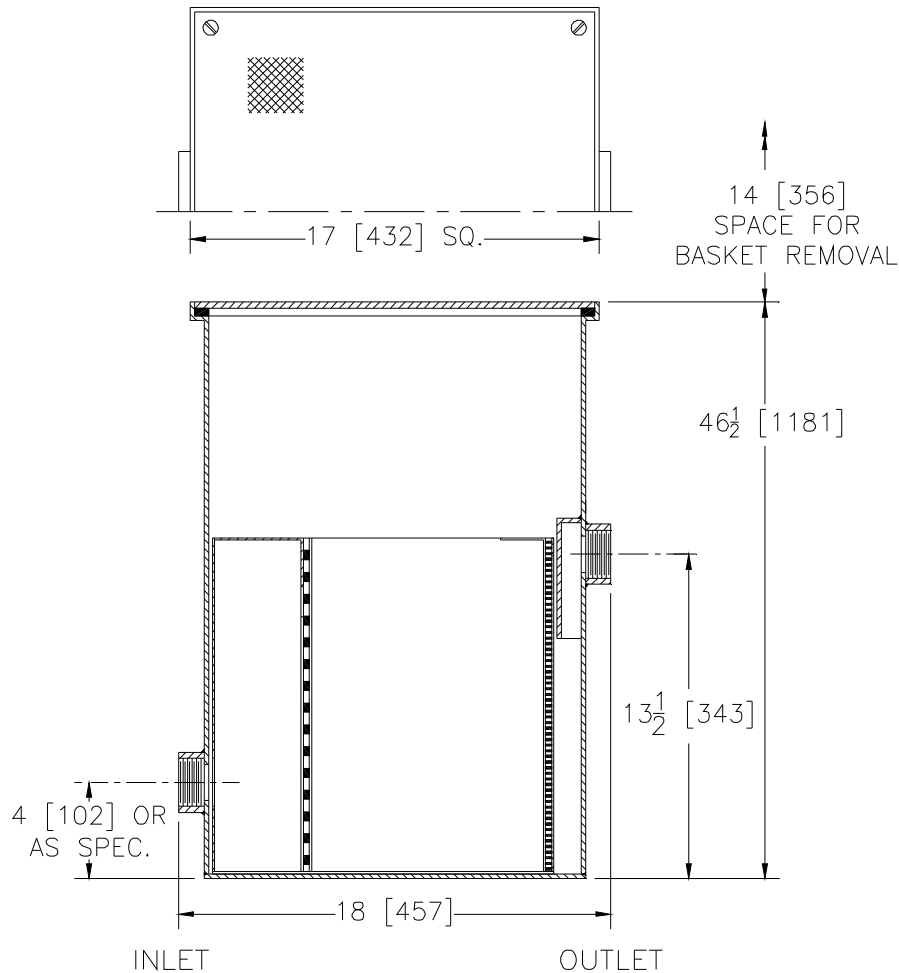

Inlet/Outlet Inches	Flow Rate GPM [L]	Approx. Wt. Lbs. [kg]
1-1/2, 2**, 3 [38, 50, 75]	30 [113]	40 [18]

### ENGINEERING SPECIFICATION: ZURN Z1181-97

Large capacity Acid Resistant Coated interior and exterior fabricated steel solids interceptor with integral extension, in lieu of fixture 'P' trap, for on-floor or flush with floor installation. Furnished with a removable Acid Resistant Coated fabricated steel bucket having removable primary (3/8 [10] dia. holes) and secondary (3/32 [2] dia. holes) flow diffusing/intercepting brass screens for animal hair applications, and complete with a top access gasketed secured cover. Regularly furnished with 2 [50] low inlet and high outlet\*\*.

**OPTIONS** (Check/specify appropriate options)

### PREFIXES

\_\_\_ Z Standard Assembly\* (See Engineering Specification)

### SUFFIXES

\_\_\_ -CS Custom Screens (Specify material & perforation size required)  
 \_\_\_ -SS Stainless Steel Perforated Screens for Bucket (Specify perforation size)  
 \_\_\_ -YR Replacement Basket Assembly with Perforated Screens

**NOTE:** 14 [356] space for basket removal may increase as overall height increases.

\* Regularly furnished unless otherwise specified.