

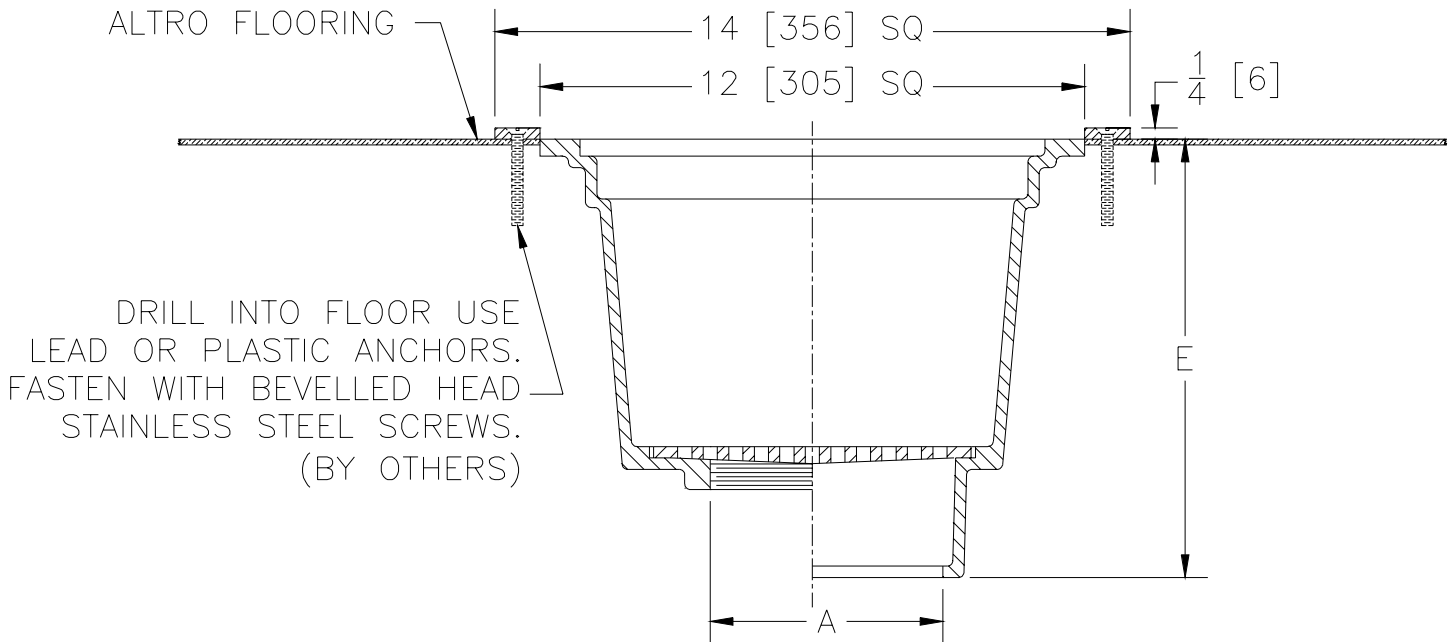

Z-566-83
12" [305] SQUARE OPEN TOP DRAIN

TAG _____

Dimensional Data (inches and [mm]) are Subject to Manufacturing Tolerances and Change Without Notice



A- Pipe Size In.	Approx. Wt. Lbs. [kg]
2-3-4 [50-75-100]	42 [19]

ENGINEERING SPECIFICATION: ZURN Z-566-83 12 [305] Square open top drain, Dura-Coated cast iron body with bottom outlet, loose set cast iron secondary strainer, and 14[356] Square Stainless Steel altro flooring Clamping Frame.

OPTIONS (Check/specify appropriate options)

PIPE SIZE

- 2, 3, 4 [50, 75, 100]
- 2, 3, 4 [50, 75, 100]
- 3, 4 [75, 100]
- 2, 3, 4 [50, 75, 100]

(Specify size/type) **OUTLET**

- _____ IC Inside Caulk
- _____ IG Inside Caulk w/Sealtrol Gskt.
- _____ IP Threaded
- _____ NL Neo-Loc

'E' BODY HT. DIM.

- 9 5/8 [244]
- 9 5/8 [244]
- 7 5/8 [194]
- 9 [229]

PREFIXES

- _____ Z- D.C.C.I. Body and Top*
- _____ ZB- D.C.C.I. Body with Polished Bronze Top (Add 3/16 [5] to 'E' Dim.)
- _____ ZN- D.C.C.I. Body with Polished Nickel Bronze Top (Add 3/16 [5] to 'E' Dim.)

SUFFIXES

- _____ -AR Acid Resisting Epoxy Coated Finish
- _____ -BT Bell Trap Bucket
- _____ -G Galvanized Cast Iron
- _____ -GT Top Grate
- _____ -Y Sediment Bucket

REV.	DATE: 9/20/00	C.N. NO. 85885
DWG. NO. P-14799 PRODUCT NO. Z-566-83		

*REGULARLY FURNISHED UNLESS OTHERWISE SPECIFIED