



# Z100-217

# SPECIFICATION SHEET

## 15 [381] DIAMETER ROOF DRAIN W/ 2 [51] DIAMETER STANDPIPE & CLEANOUT FERRULE WITH PLUG

TAG \_\_\_\_\_

Dimensional Data (inches and [mm]) are Subject to Manufacturing Tolerances and Change Without Notice

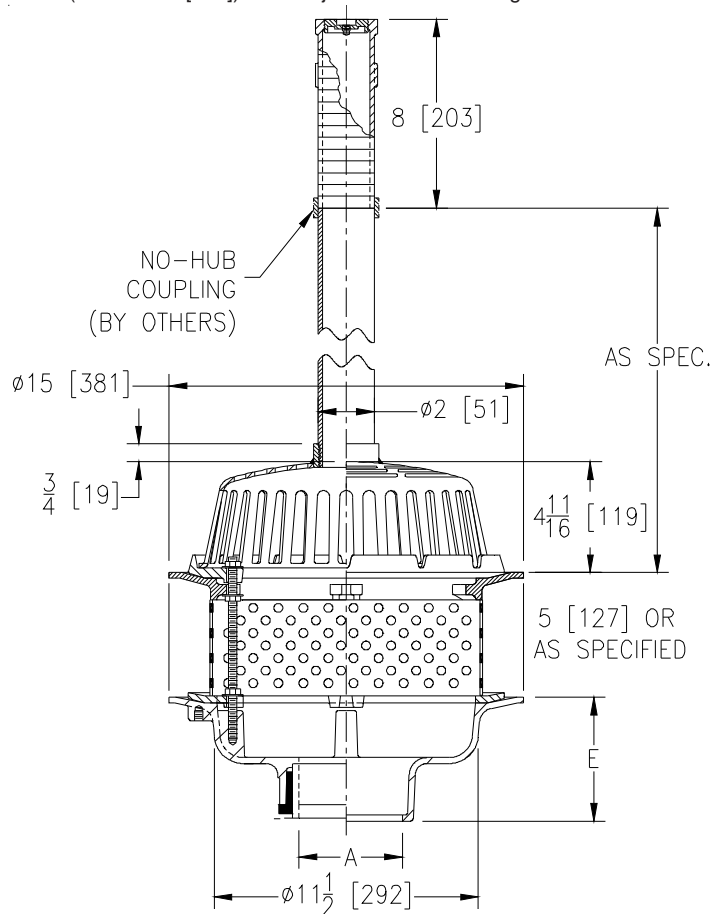

A Pipe Size In.	Approx. Wt. Lbs. [kg]	Dome Open Area Sq. In. [cm <sup>2</sup> ]
2-3-4 [50-75-100]	26 [12]	103 [665]
5-6 [125-150]	27 [12]	
8 [200]	28 [13]	

### ENGINEERING SPECIFICATION: ZURN Z100-217

15 [381] Diameter roof drain. Dura-Coated cast iron body with combination membrane flashing clamp/gravel guard and low silhouette cast iron dome, perforated stainless steel extension, static extension, secondary clamp collar, 2 [51] standpipe, and Z1449 Cleanout ferrule with plug.

### OPTIONS (Check/specify appropriate options)

#### PIPE SIZE

- 2 thru 6, 8 [50 thru 150,200]
- 2 thru 6, 8 [50 thru 150,200]
- 2 thru 6, 8 [50 thru 150,200]
- 2,3,4 [50,75,100]

#### (Specify size/type) OUTLET

- \_\_\_\_\_ IC Inside Caulk
- \_\_\_\_\_ IP Threaded
- \_\_\_\_\_ NH No-Hub
- \_\_\_\_\_ NL Neo-Loc

#### E BODY HT. DIM.

- 5 1/4 [133]
- 3 3/4 [95]
- 5 1/4 [133]
- 4 5/8 [117]

#### PREFIXES

- \_\_\_\_\_ ZC D.C.C.I. Body with Cast Iron Dome and Cleanout Ferrule with ABS Plug\*

#### SUFFIXES

- |   |   |
|---|---|
| _____ -AC Angular Underdeck Clamp                                     | _____ -R Roof Sump Receiver                     |
| _____ -AR Acid Resistant Epoxy Coated Finish                          | _____ -SC Secondary Clamping Collar             |
| _____ -BS Bronze Mesh Screen Over Dome                                | _____ -SS Stainless Steel Mesh Screen Over Dome |
| _____ -C Underdeck Clamp  | _____ -VP Vandal Proof Secured Top              |
| _____ -EA Adjustable Extension Assembly<br>1 3/4 [44] thru 3 1/2 [89] | _____ -XJ Vertical Expansion Joint (See Z-190)  |
| _____ -G Galvanized Cast Iron   | _____ -90 90° Threaded Side Outlet Body         |
| _____ -GD Galvanized Cast Iron Dome                                   |   |

\*REGULARLY FURNISHED UNLESS OTHERWISE SPECIFIED

REV. DATE: 12/28/09 C.N. NO. 110544

DWG. NO. P-15815 PRODUCT NO. Z100-217

ZURN INDUSTRIES, LLC. ♦ SPECIFICATION DRAINAGE OPERATION ♦ 1801 Pittsburgh Ave. ♦ Erie, PA 16514

Phone: 814/455-0921 ♦ Fax: 814/454-7929 ♦ World Wide Web: www.zurn.com

In Canada: ZURN INDUSTRIES LIMITED ♦ 3544 Nashua Drive ♦ Mississauga, Ontario L4V1L2 ♦ Phone: 905/405-8272 Fax: 905/405-1292