



Z100-197

15 [381] DIA. MAIN ROOF DRAIN W/ TOP-SET® ADJUSTABLE EXTENSION ASSEMBLY & 2 [51] HIGH INTERNAL WATER DAM

SPECIFICATION SHEET

TAG _____

Dimensional Data (inches and [mm]) are Subject to Manufacturing Tolerances and Change Without Notice

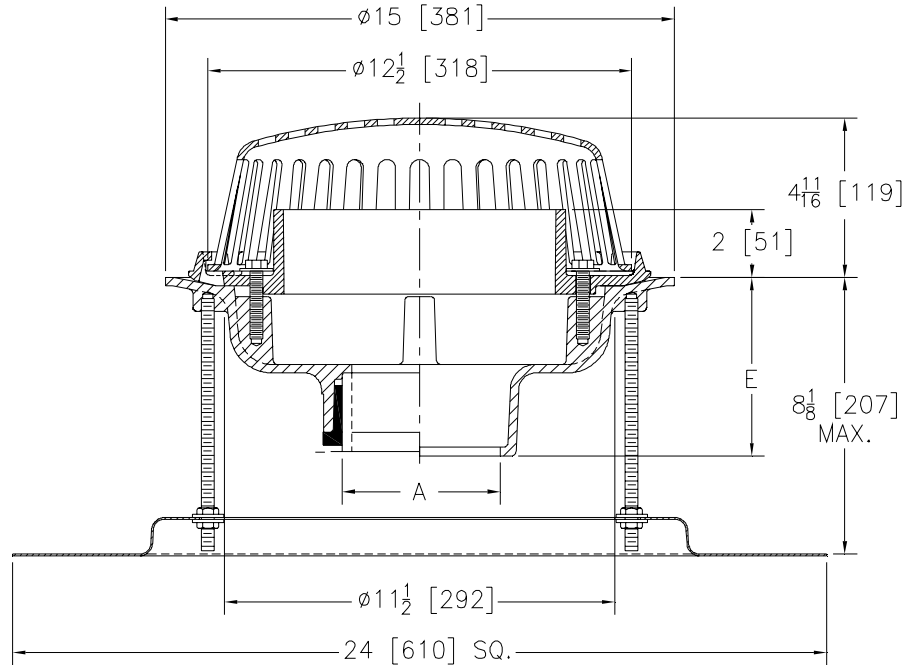

A- Pipe Size In.	Approx. Wt. Lbs. [kg]	Dome Open Area Sq. In. [cm ²]
2-3-4 [51-76-102]	36 [16]	103 [665]
5-6 [127-152]	37 [17]	
8 [203]	38 [17]	

ENGINEERING SPECIFICATION: ZURN Z100-197
15 [381] Diameter roof drain. Dura-Coated cast iron body with combination membrane flashing clamp/gravel guard, top-set® adjustable extension assembly, 2 [51] high internal water dam and low silhouette Poly-Dome.

OPTIONS (Check/specify appropriate options)

PIPE SIZE

- 2 thru 6-8 [51 thru 152-203]
- 2 thru 6-8 [51 thru 152-203]
- 2 thru 6-8 [51 thru 152-203]
- 2-3-4 [51-76-102]

(Specify size/type) **OUTLET**

- _____ IC Inside Caulk
- _____ IP Threaded
- _____ NH No-Hub
- _____ NL Neo-Loc

E BODY HT. DIM.

- 5 1/4 [133]
- 3 3/4 [95]
- 5 1/4 [133]
- 4 5/8 [117]

PREFIXES

- _____ Z D.C.C.I. Body with Poly-Dome*
- _____ ZA D.C.C.I. Body with Aluminum Dome
- _____ ZC D.C.C.I. Body with Cast Iron Dome
- _____ ZRB D.C.C.I. Body with Plain Bronze Dome

SUFFIXES

- _____ -AR Acid Resistant Epoxy Coated Finish
- _____ -BS Bronze Mesh Screen Over Dome
- _____ -G Galvanized Cast Iron
- _____ -GD Galvanized Cast Iron Dome
- _____ -HD 6 3/4 [171] High Aluminum Dome (148 Sq. In. [955 cm²] Open Area)(ZA only)
- _____ -SC Secondary Clamping Collar
- _____ -SS Stainless Steel Mesh Screen Over Dome
- _____ -TC Neo-Loc Test Cap Gasket (2 - 4 [51 - 102] NL Bottom Outlet Only)
- _____ -VP Vandal-Proof Secured Top

REV.	DATE: 12/08/08	C.N. NO. 99460
DWG. NO. P-15633	PRODUCT NO. Z100-197	

*REGULARLY FURNISHED UNLESS OTHERWISE SPECIFIED