



Z531-79

SPECIFICATION SHEET

9 [229] DIAMETER ADJUSTABLE FRAME WIDE FLANGE DECK DRAIN W/ SEDIMENT BUCKET AND SOLID GASKETED COVER

TAG _____

Dimensional Data (inches and [mm]) are Subject to Manufacturing Tolerances and Change Without Notice

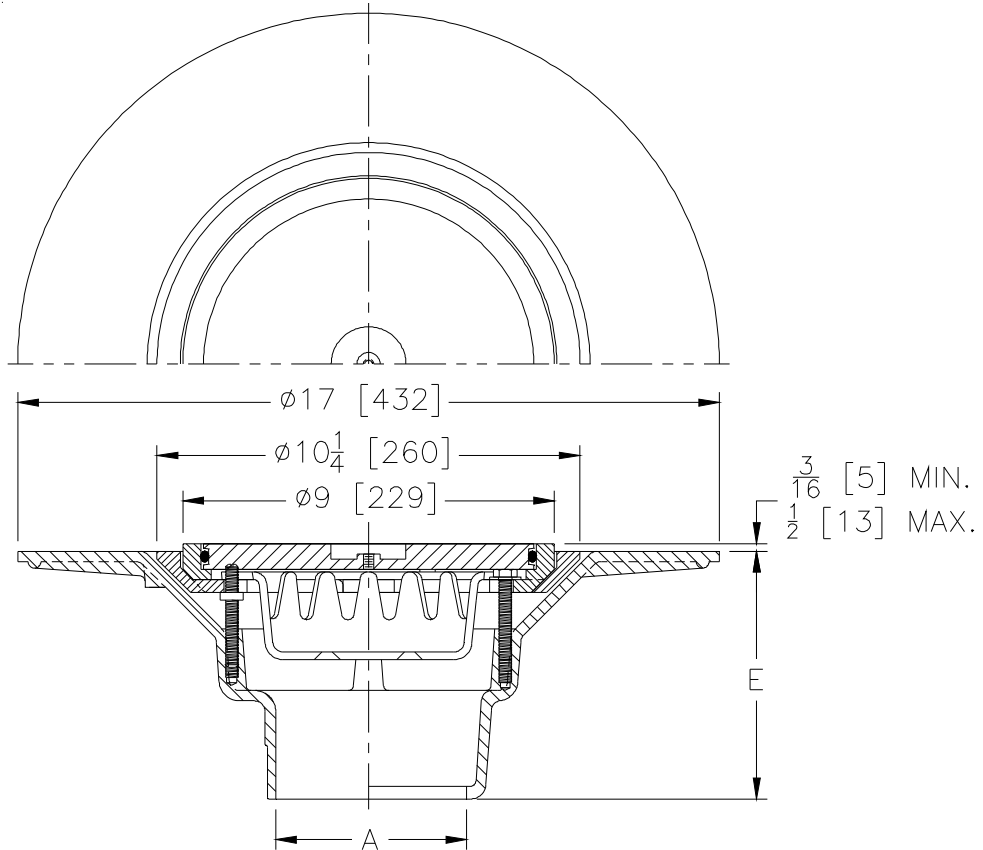

A Pipe Size In.	Approx. Wt. Lbs. [kg]
2-3-4 [51-76-102]	54 [24]

ENGINEERING SPECIFICATION: ZURN Z531-79

9 [229] Diameter adjustable frame wide flange deck drain, Dura-Coated cast iron body with 10-1/4 [260] diameter latex troweling flange and combination adjustable latex troweling-edge-form, membrane flashing clamp with gasketed solid cover and sediment bucket.

OPTIONS (Check/specify appropriate options)

PIPE SIZE

- 2 thru 4 [51 thru 102]
- 2 thru 4 [51 thru 102]
- 2 thru 4 [51 thru 102]
- 2 thru 4 [51 thru 102]
- 2 thru 4 [51 thru 102]

(Specify size/type) **OUTLET**

- ___ IC Inside Caulk
- ___ IG Inside Caulk w/Sealtrol Gskt.
- ___ IP Threaded
- ___ NH No-Hub
- ___ NL Neo-Loc

'E' BODY HT. DIM.

- 6 [152]
- 6 [152]
- 4-1/2 [114]
- 6 [152]
- 5-3/8 [136]

PREFIXES

- ___ Z D.C.C.I. Body and Cover*
- ___ ZB D.C.C.I. Body with Polished Bronze Cover
- ___ ZN D.C.C.I. Body with Polished Nickel Bronze Cover

SUFFIXES

- ___ -C Clamp Collar
- ___ -G Galvanized Cast Iron
- ___ -S Secondary Strainer
- ___ -TC Neo-Loc Test Cap Gasket
(2 [51]-4 [102] NL Bottom Outlet Only)
- ___ -TS Top Secured with Slotted Screws
- ___ -VP Vandal-Proof Secured Top

REV. A	DATE: 6/8/11	C.N. NO. 121380
DWG NO. P-13850	PRODUCT NO. Z531-79	

*REGULARLY FURNISHED UNLESS OTHERWISE SPECIFIED