



# Z1360-79

## GROUND HYDRANT

### Encased, Flush Type, Non-Freeze

SPECIFICATION SHEET

TAG \_\_\_\_\_

Dimensional Data (inches and [ mm ]) are Subject to Manufacturing Tolerances and Change Without Notice

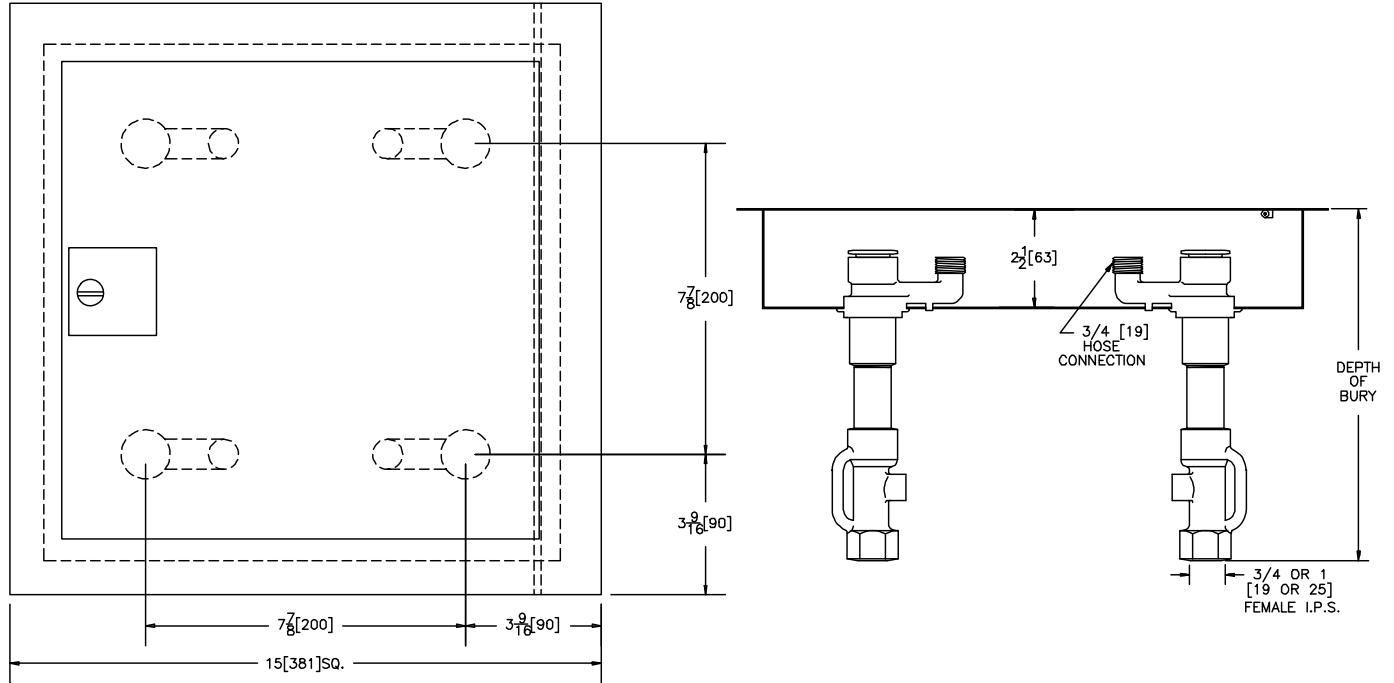

**ENGINEERING SPECIFICATION: ZURN Z1360-79**

Encased, non-freeze hydrant, for flush with grade or finished (non-traffic) floor installation. Complete with galvanized steel casing, all bronze interior parts, bronze seat and replaceable seat washer, non-turning operating rod with free-floating compression closure valve with 3/4 [19] or 1 [25] connection. Stainless steel box and continuous piano type hinged cover with latch type lock. Hydrant is equipped with a tapped 1/4 [6] drain port in valve housing.

Note:

- IMPORTANT** Hydrant must be opened one turn to seal drain port during use.

**OPTIONS** (Check/specify appropriate options)

**SUFFIXES**

- \_\_\_\_\_ -**AQD** With Opening in Bottom of Box for Air Quick Disconnect Pipe
- \_\_\_\_\_ -**BC** Bronze Casing
- \_\_\_\_\_ -**DP14** 1/4 [6] Drain Port in Box
- \_\_\_\_\_ -**RK** Hydrant Parts Repair Kit
- \_\_\_\_\_ -**VB** 3/4 [19] Adapter Vacuum Breaker

<b>REV. A</b>	<b>DATE: 05/05/08</b>	<b>C.N. NO. 98441</b>
<b>DWG. NO. P-14223</b>	<b>PRODUCT NO. Z1360-79</b>	