



Z541-P

12 [305] DIAMETER HEAVY-DUTY DRAIN W/ TRAP PRIMER CONNECTION

TAG _____

Dimensional Data (inches and [mm]) are Subject to Manufacturing Tolerances and Change Without Notice

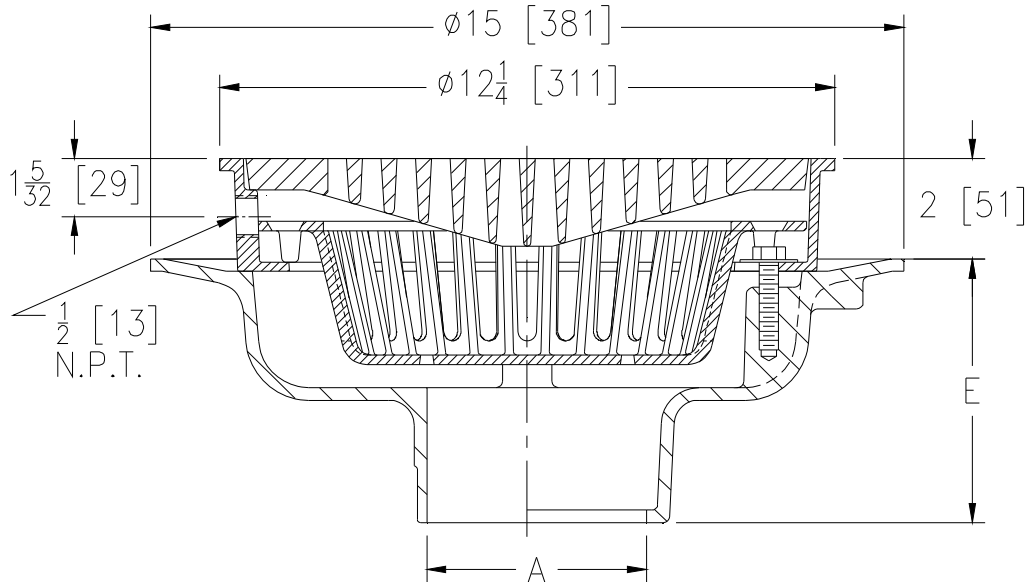

A- Pipe Size In.	Approx. Wt. Lbs. [kg]	Grate Open Area Sq. In. [cm ²]
2-3-4-5-6 [51-76-102-127-152]	52 [24]	30 [194]
8-10 [203-254]	54 [24]	

ENGINEERING SPECIFICATION: ZURN Z541-P

12 [305] Diameter top drain. Dura-Coated cast iron body with bottom outlet, seepage pan and combination membrane flashing clamp and frame w/ 1/2 [13] trap primer connection for anti-tilt heavy-duty slotted grate with suspended polypropylene sediment bucket.

OPTIONS (Check/specify appropriate options)

PIPE SIZE

- 2 thru 6, 8, 10 [51 thru 152, 203, 254]
- 2 thru 6, 8, 10 [51 thru 152, 203, 254]
- 2 thru 6, 8, 10 [51 thru 152, 203, 254]
- 2 thru 6, 8, 10 [51 thru 152, 203, 254]
- 2 thru 4 [51 thru 102]

(Specify size/type) OUTLET

- ___ IC Inside Caulk
- ___ IG Inside Caulk w/Sealtrol Gskt.
- ___ IP Threaded
- ___ NH No-Hub
- ___ NL Neo-Loc

'E' BODY HT. DIM.

- 5 1/4 [133]
- 5 1/4 [133]
- 3 3/4 [95]
- 5 1/4 [133]
- 4 5/8 [117]

PREFIXES

- ___ Z D.C.C.I. Body and Top*
- ___ ZB D.C.C.I. Body w/ Polished Bronze Top (Add 3/16 [5] to 2 [51] Dim. and 3/4 [19] to 12 1/4 [311] Dim.)
- ___ ZN D.C.C.I. Body w/ Polished Nickel Bronze Top (Add 3/16 [5] to 2 [51] Dim. and 3/4 [19] to 12 1/4 [311] Dim.)

SUFFIXES

- ___ -AR Acid Resisting Epoxy Coated Cast Iron
- ___ -D Dome Grate (D.C.C.I. only)
- ___ -DG Duresist Grate
- ___ -G Galvanized Cast Iron
- ___ -H Hinged Grate
- ___ -HP Heel-Proof Grate
- ___ -LY (Less) Sediment Bucket
- ___ -PH Packing House Grate
- ___ -S Secondary Strainer
- ___ -SS Stainless Mesh Liner for Bucket
- ___ -TC Neo-Loc Test Cap Gasket (2 [51] - 4 [102] NL Bottom Outlet Only)
- ___ -TG Tractor Grate
- ___ -TS Top Secured with Slotted Screws
- ___ -V Backwater Valve (See Z1099)
- ___ -VP Vandal-Proof Secured Top
- ___ -WS Wide Slotted Grate (50 sq. in open)
- ___ -YC Cast Iron Sediment Bucket
- ___ -90 90° Threaded Side Outlet Body (2 thru 6 [50 thru 150])

*REGULARLY FURNISHED UNLESS OTHERWISE SPECIFIED

REV. A	DATE: 9/9/09	C.N. NO. 110178
DWG. NO. 83392	PRODUCT NO. Z541-P	